

Rev	Revisions	Rev.Drawn	Date
A		Du	18.FEB.2013

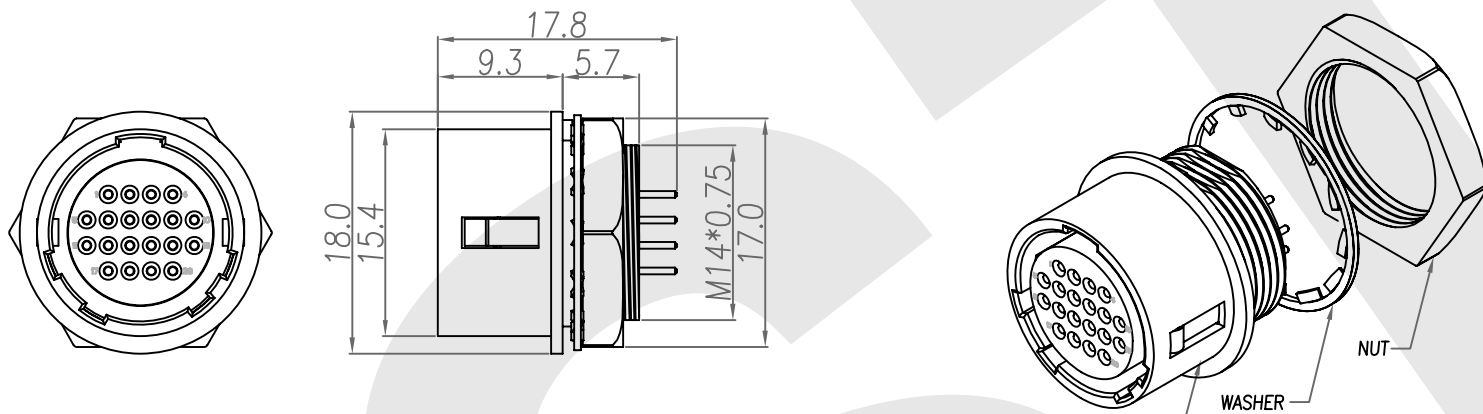

1. MATERIAL :
- 1-1. HOUSING : NYLON46 UL94V-0; COLOR : BLACK
 - 1-2. CONTACT : BRASS
 - 1-3. SHELL : ZINC ALLOY
 - 1-4. SPRING : STAINLESS STEEL
 - 1-5. WASHER : PHOSPHOR BRONZE
 - 1-6. NUT : BRASS
2. FINISH :
- 2-1. CONTACT : GOLD FLASH
 - 2-2. SHELL : NICKEL
 - 2-3. WASHER : NICKEL
 - 2-4. NUT : NICKEL

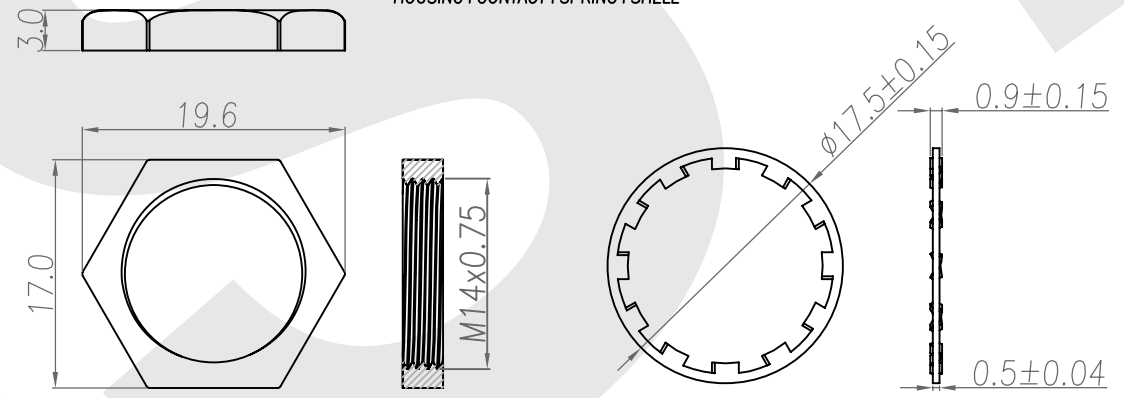

3. ORDERING INFORMATION : P-P(PUSH PULL) CONNECTOR

Series ST4A-14BR-20S-D

Dimension of inner thread=M14

Poles P: Male contact S: Female contact

P: Plug

WR: Wire Receptacle
BR: Panel / Case Receptacle

D: Dip type
S: Solder type

SGS Report No.:		SST SOUTH SEA TERMINAL CO.,LTD		Customer:		Part No.:	
		1:1		QC5838		ST4A-14BR-20S-D	
Drawn By: Storm.Li		Checked By: du		Title: P-P CONN. Panel / Case Receptacle Dip Type (F)		TOLERANCE:	
Approved By: Tony		General Dimension Tolerance		Units mm		.x ±0.20 .xx ±0.15 .xxx ±0.05 .xxxx ±0.03 ANGULA ±1°	

Rev	Revisions	Rev.Drawn	Date
A		Du	18.FEB.2013

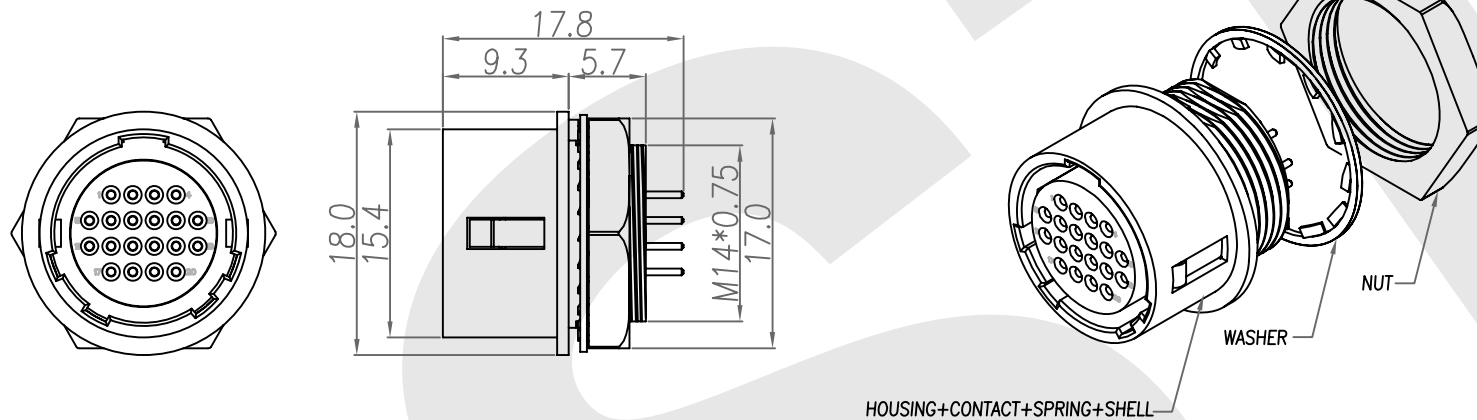

1. MATERIAL :
- 1-1. HOUSING : NYLON46 UL94V-0; COLOR : BLACK
 - 1-2. CONTACT : BRASS
 - 1-3. SHELL : ZINC ALLOY
 - 1-4. SPRING : STAINLESS STEEL
 - 1-5. WASHER : PHOSPHOR BRONZE
 - 1-6. NUT : BRASS
2. FINISH :
- 2-1. CONTACT : GOLD FLASH
 - 2-2. SHELL : NICKEL
 - 2-3. WASHER : NICKEL
 - 2-4. NUT : NICKEL

SST SOUTH SEA TERMINAL CO.,LTD

SGS Report No.:	Customer:	Part No.:
		ST4A-14BR-20S-D
Title: P-P CONN. Panel / Case Receptacle Dip Type (F) (SHELL SIZE 13mm)		
Drawn By: Storm.Li	SCALE	SHEET
Checked By: du	1:1	2/2
Approved By: Tony	REV.	A
	DWG NO.:	QC5838
	Third angle Projection	Units
	General Dimension Tolerance	mm
	TOLERANCE:	
	.x	±0.20
	.xx	±0.15
	.xxx	±0.05
	.xxxx	±0.03
	ANGULA	±1°