

Rev	Revisions	Rev.Drawn	Date
A		Du	18.FEB.2013

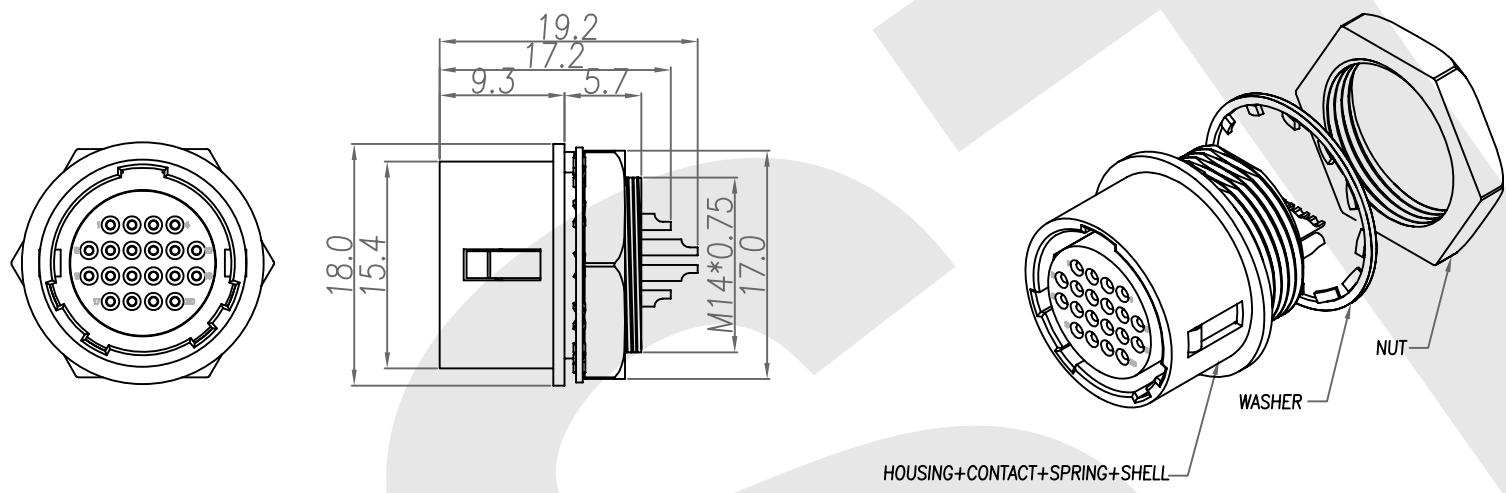

1. MATERIAL :
- 1-1. HOUSING : NYLON46 UL94V-0; COLOR : BLACK
 - 1-2. CONTACT : BRASS
 - 1-3. SHELL : ZINC ALLOY
 - 1-4. SPRING : STAINLESS STEEL
 - 1-5. WASHER : PHOSPHOR BRONZE
 - 1-6. NUT : BRASS
2. FINISH :
- 2-1. CONTACT : GOLD FLASH
 - 2-2. SHELL : NICKEL
 - 2-3. WASHER : NICKEL
 - 2-4. NUT : NICKEL

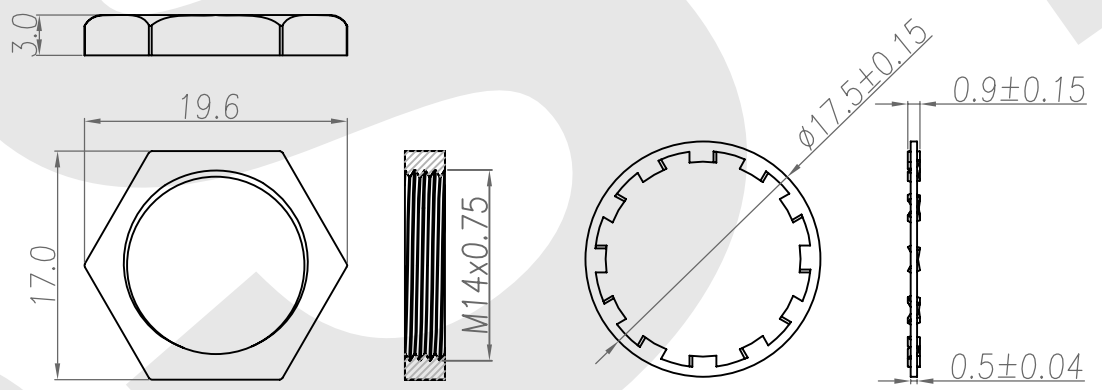

3. ORDERING INFORMATION : P-P(PUSH PULL) CONNECTOR

Series ST4A-14BR-20S-S

Dimension of inner thread=M14

Poles: P: Male contact, S: Female contact

P: Plug, WR: Wire Receptacle, BR: Panel / Case Receptacle

D: Dip type, S: Solder type

SGS Report No.:		SST SOUTH SEA TERMINAL CO.,LTD			Part No.: ST4A-14BR-20S-S	
		Customer:			Title: P-P CONN. Panel / Case Receptacle Solder Type(F) (SHELL SIZE 13mm)	
Drawn By: Storm.Li	SCALE: 1:1	SHEET: 1/2	REV.: A	DWG NO.: QC5836	TOLERANCE:	
Checked By: du	Thire angle Projection			Units: mm	.x ±0.20	.xx ±0.15
Approved By: Tony	General Dimesion Tolerance				.xxx ±0.05	.xxxx ±0.03

Rev	Revisions	Rev.Drawn	Date
A		Du	18.FEB.2013

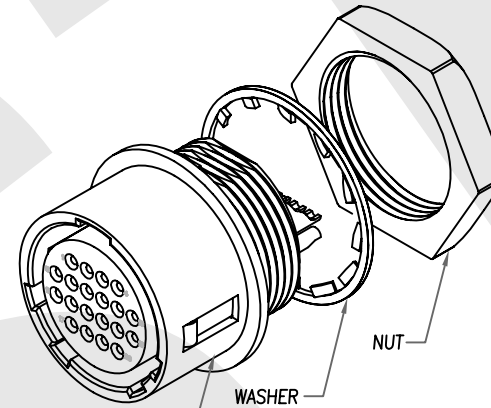
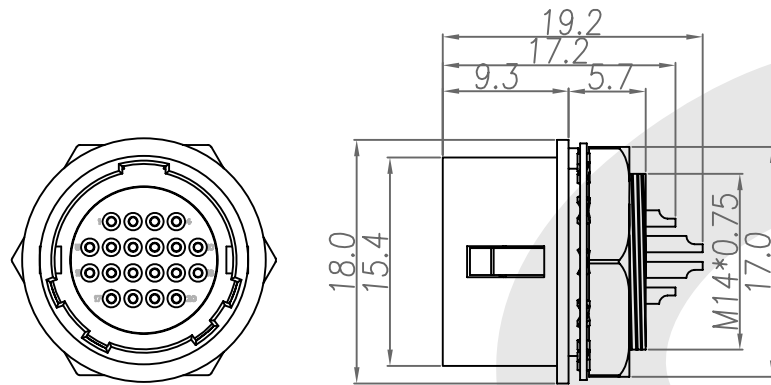

HOUSING+CONTACT+SPRING+SHELL

1. MATERIAL :
 - 1-1. HOUSING : NYLON46 UL94V-0; COLOR : BLACK
 - 1-2. CONTACT : BRASS
 - 1-3. SHELL : ZINC ALLOY
 - 1-4. SPRING : STAINLESS STEEL
 - 1-5. WASHER : PHOSPHOR BRONZE
 - 1-6. NUT : BRASS

2. FINISH :
 - 2-1. CONTACT : GOLD FLASH
 - 2-2. SHELL : NICKEL
 - 2-3. WASHER : NICKEL
 - 2-4. NUT : NICKEL

SST SOUTH SEA TERMINAL CO.,LTD

SGS Report No.:	Customer:	Part No.:
		ST4A-14BR-20S-S
Title: P-P CONN. Panel / Case Receptacle Solder Type(F) (SHELL SIZE 13mm)		
Drawn By: Storm.Li	SCALE	SHEET
Checked By: du	1:1	2/2
Approved By: Tony	REV.	A
	DWG NO.:	QC5836
	Third angle Projection	Units
	General Dimension Tolerance	mm
		TOLERANCE:
		.x ±0.20
		.xx ±0.15
		.xxx ±0.05
		.xxxx ±0.03
		ANGULA ±1°