

Rev	Revisions	Rev.Drawn	Date
A		Du	24.Aug.2012

1. MATERIAL :

- 1-1. HOUSING : NYLON 46 UL94V-0 ; COLOR : BLACK
- 1-2. CONTACT : PHOSPHOR BRONZE
- 1-3. SHELL A : Zinc Alloy
- 1-4. SHELL B : BRASS
- 1-5. O-RING A : NBR; COLOR : BLACK
- 1-6. SCREW : ALLOY STEEL
- 1-7. CLAMP : BRASS
- 1-8. SR : TPR

2. FINISH :

- 2-1. CONTACT A : 5 MICRO INCHES MIN. GOLD PLATED
- 2-2. SHELL A : NICKEL PLATED 60u" ~ 100u" OVER ALL
- 2-3. SHELL B : NICKEL PLATED 60u" ~ 100u" OVER ALL
- 2-4. SCREW : NICKEL PLATED 60u" ~ 100u" OVER ALL

3. ORDERING INFORMATION : P-P(PUSH PULL) CONNECTOR

Series ST2A-08WR-XXS-S

Dimension of inner thread=M8

Poles: P: Plug, S: Solder type

WR: Wire Receptacle, BR: Panel / Case Receptacle

D: Dip type, S: Solder type

P: Male contact, S: Female contact

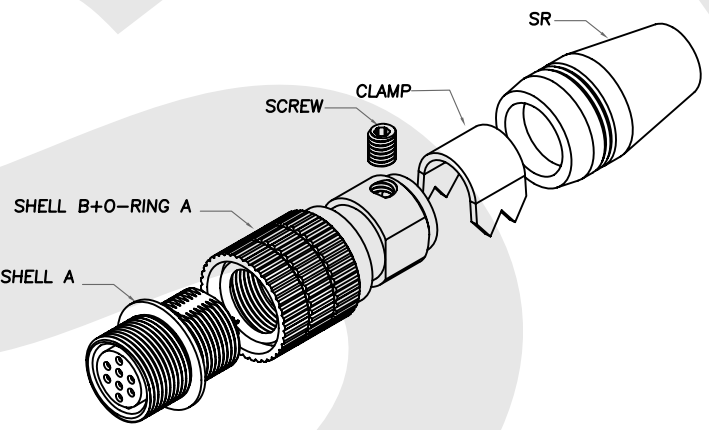
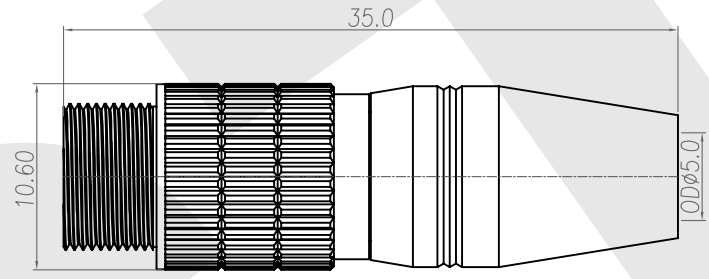
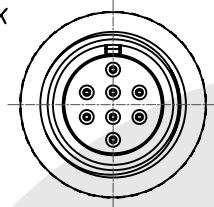

ST2A-08WR-04S-S

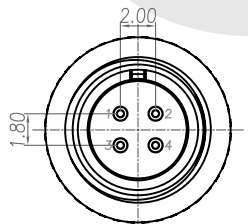

ST2A-08WR-06S-S

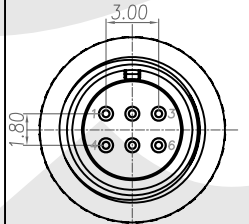

ST2A-08WR-08S-S

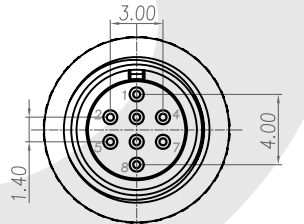

SST SOUTH SEA TERMINAL CO.,LTD

SGS Report No.:	Customer:	Part No.:
		ST2A-08WR-XXS-S
Title: P-P CONN. Wire Receptacle Solder Type (F)		
Drawn By: Storm.Li	SCALE: 1:1	SHEET: 1/2
Checked By: du	REV: A	DWG NO.: QC5631
Approved By: Tony	TOLERANCE: .x ±0.20 .xx ±0.10 .xxx ±0.05 .xxxx ±0.03 ANGULA ±1°	
Third angle Projection		Units: mm
General Dimension Tolerance		

Rev	Revisions	Rev.Drawn	Date
A		Du	24.Aug.2012

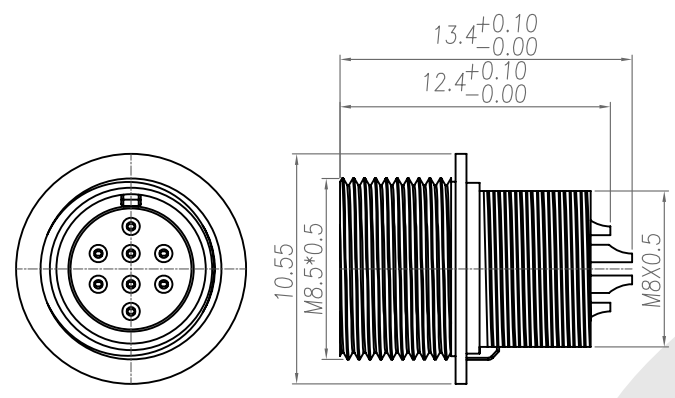

HOUSING+CONTACT+SHELL A

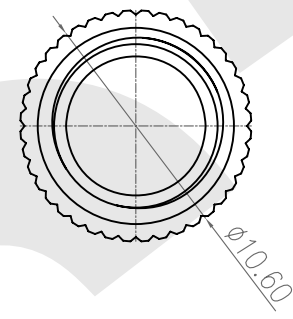

SHELL B+O-RING A

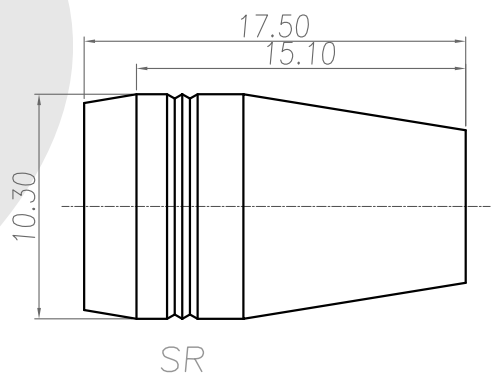
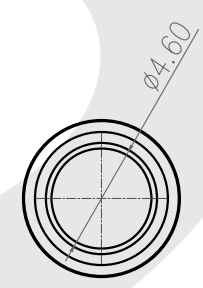
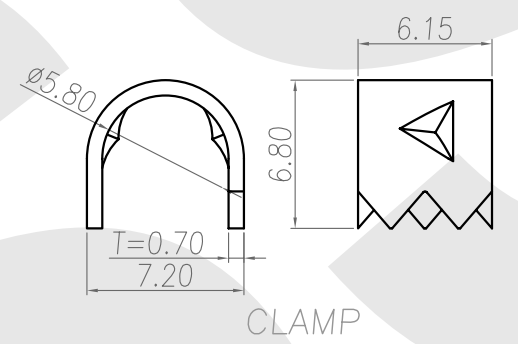
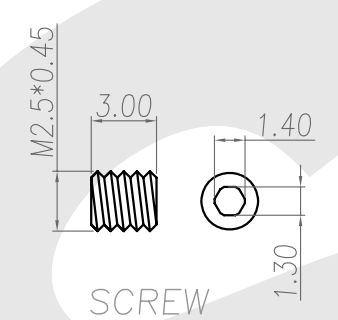
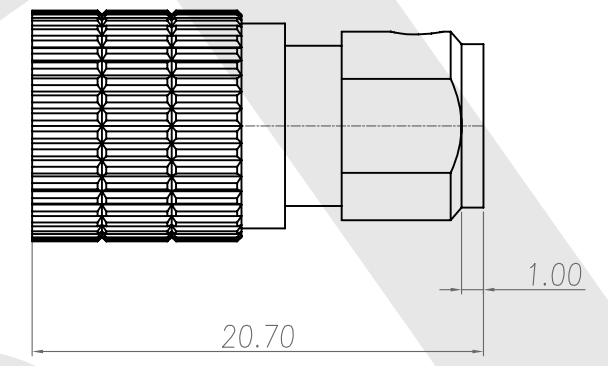

SST SOUTH SEA TERMINAL CO.,LTD

SGS Report No.:	Customer:	Part No.:
		ST2A-08WR-XXS-S
Title: P-P CONN. Wire Receptacle Solder Type (F)		
Drawn By: Storm.Li	SCALE	SHEET
Checked By: du	1:1	2/2
Approved By: Tony	REV.	A
	DWG NO.:	QC5631
	TOLERANCE:	
	.x ±0.20	
	.xx ±0.10	
	.xxx ±0.05	
	.xxxx ±0.03	
	ANGULA ±1°	
	Thire angle Projection	Units
	General Dimesion Tolerance	mm