

Rev	Revisions	Rev.Drawn	Date
A		Du	21.DEC.2011

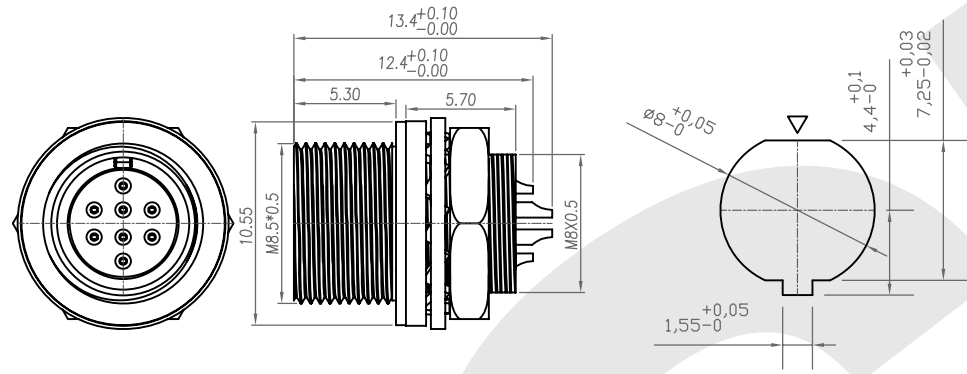

- MATERIAL :**
 - 1-1. HOUSING : NYLON 46 ; COLOR : BLACK
 - 1-2. CONTACT : PHOSPHOR BRONZE
 - 1-3. SHELL : Zinc Alloy
 - 1-4. NUT : BRASS
 - 1-5. O-RING : EPDM; COLOR : BLACK
 - 1-6. WASHER : BRASS
- FINISH :**
 - 2-1. CONTACT : GOLD 5u"
 - UNDER PLATE : NICKEL
 - 2-2. SHELL : NICKEL PLATED .
 - 2-3. NUT : NICKEL PLATED.

RECOMMEND PANEL CUT-OUT

3. ORDERING INFORMATION : P-P(PUSH PULL) CONNECTOR

Series ST2A-08BR-XXS-S

Dimension of inner thread=M8

Poles: P: Plug, S: Solder type

WR: Wire Receptacle, BR: Panel / Case Receptacle

D: Dip type, S: Solder type

P: Male contact, S: Female contact

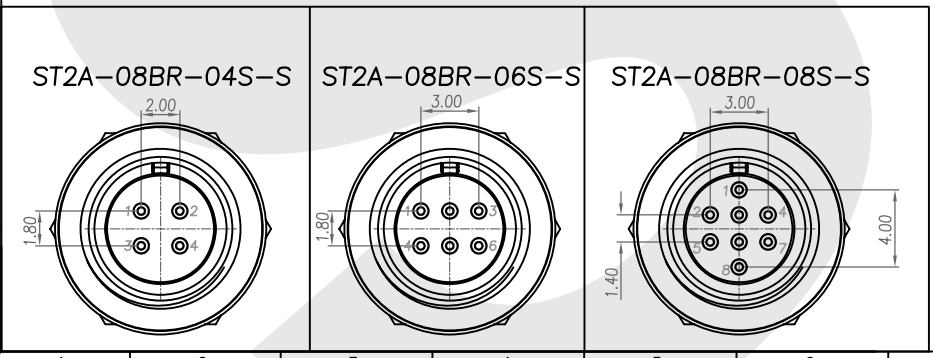
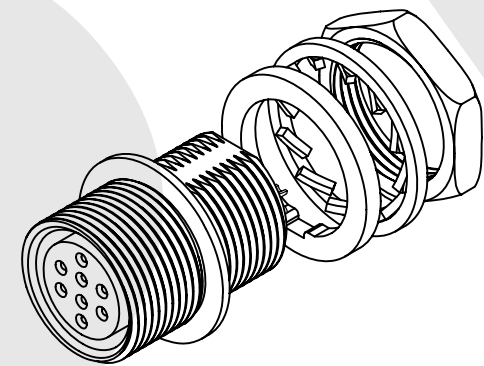

SST SOUTH SEA TERMINAL CO.,LTD

SGS Report No.:	Customer:	Part No.:	ST2A-08BR-XXS-S		
Title: P-P CONN Panel / Case Receptacle Solder Type(F)					
Drawn By: Storm.Li	SCALE	SHEET	REV.	DWG NO.:	TOLERANCE:
Checked By: du	1:1	1/2	A	QC5174	.x ±0.20
Approved By: Tony	Thire angle Projection		General Dimesion Tolerance		.xx ±0.10
	Units		mm		.xxx ±0.05
	mm				.xxxx ±0.03
					ANGULA ±1°

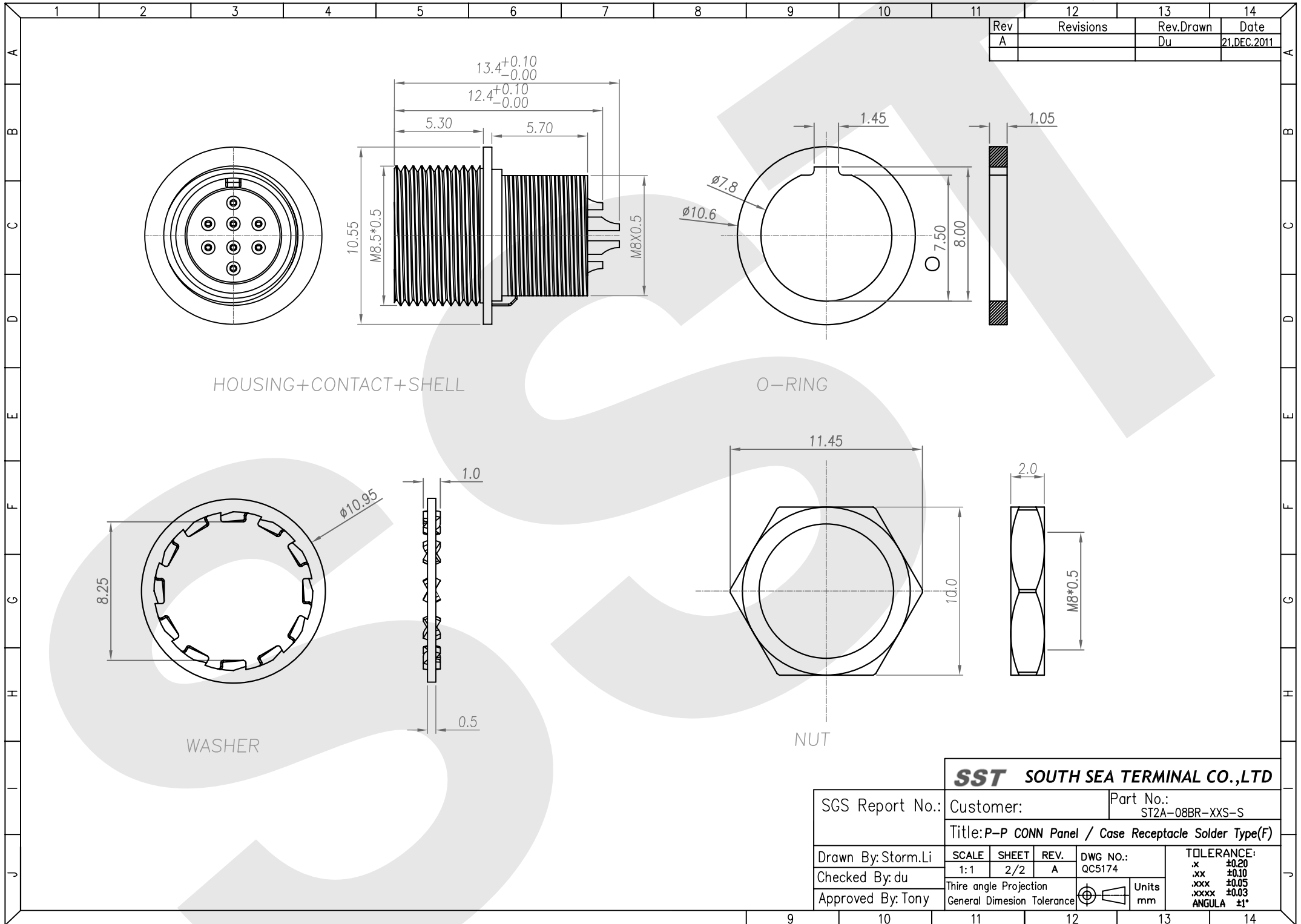

SST SOUTH SEA TERMINAL CO.,LTD

SGS Report No.: Customer: Part No.: ST2A-08BR-XXS-S

Title: P-P CONN Panel / Case Receptacle Solder Type(F)

Drawn By: Storm.Li	SCALE	SHEET	REV.	DWG NO.:	TOLERANCE: .x ±0.20 .xx ±0.10 .xxx ±0.05 .xxxx ±0.03 ANGULA ±1°
Checked By: du	1:1	2/2	A	QC5174	
Approved By: Tony	Third angle Projection			Units mm	
	General Dimension Tolerance				