

Rev	Revisions	Rev.Drawn	Date
A		Du	13.DEC.2011

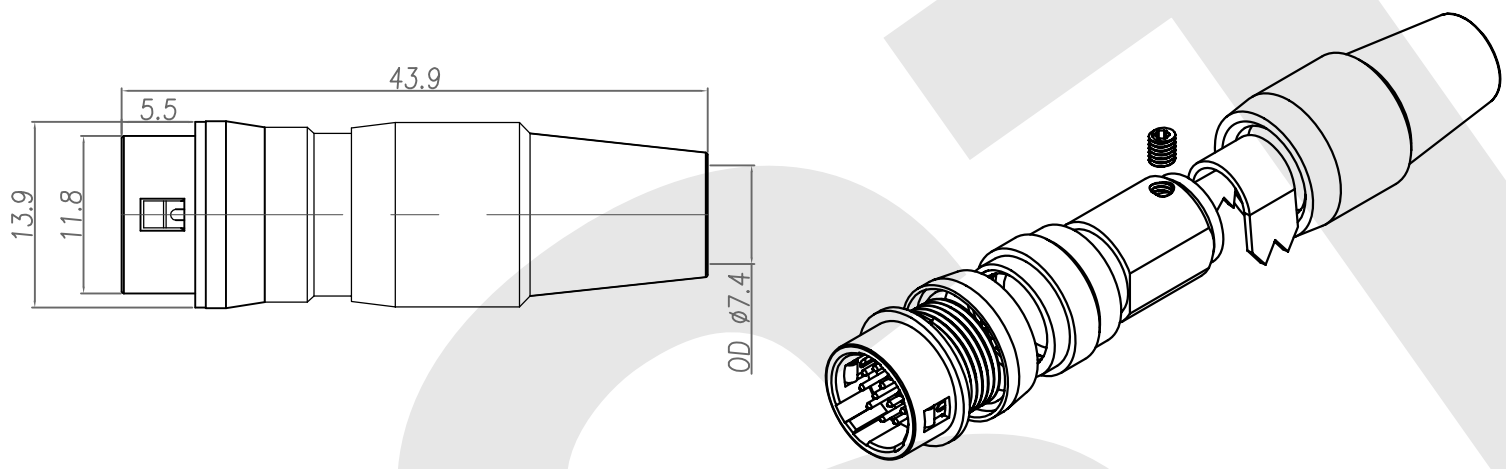
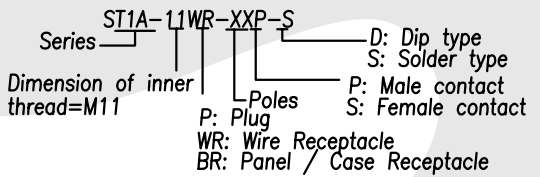

TABLE A

CONTACT ARRANGEMENT & DIMENSIONS(FRONT VIEW)	
ST1A-11WR-12P-S	ST1A-11WR-10P-S

1. MATERIAL :
- 1-1. HOUSING : NYLON46 UL94V-0  
COLOR : BLACK
  - 1-2. CONTACT : BRASS
  - 1-3. SHELL A : ZINC ALLOY
  - 1-4. SHELL B : BRASS
  - 1-5. SHELL C : BRASS
  - 1-6. SCREW : ALLOY STEEL
  - 1-7. CLAMP : BRASS
  - 1-8. SR : TPR ; COLOR : BLACK
2. FINISH :
- 2-1. CONTACT : GOLD FLASH
  - 2-2. SHELL A : NICKEL
  - 2-3. SHELL B : NICKEL
  - 2-4. SHELL C : NICKEL
  - 2-5. SCREW : NICKEL

3. ORDERING INFORMATION : P-P(PUSH PULL) CONNECTOR



SGS Report No.:		Customer:		Part No.:	
				ST1A-11WR-XXP-S	
Title: P-P CONN. Wire Receptacle Solder Type(M)					
Drawn By: Storm.Li	SCALE	SHEET	REV.	DWG NO.:	TOLERANCE:
Checked By: du	1:1	1/2	A	QC5611	.x ±0.20
Approved By: Tony	Thire angle Projection		General Dimesion Tolerance		.xx ±0.10
		Units		.xxx ±0.05	
		mm		.xxxx ±0.03	
				ANGULA ±1°	

Rev	Revisions	Rev.Drawn	Date
A		Du	13.DEC.2011

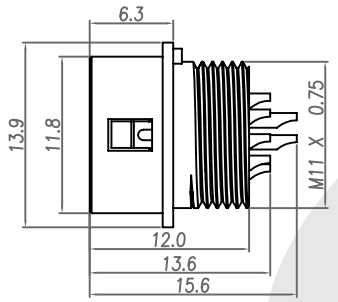
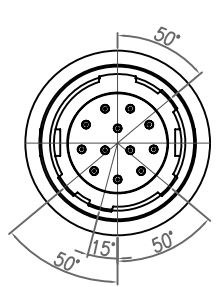

HOUSING + CONTACT + SHELL A

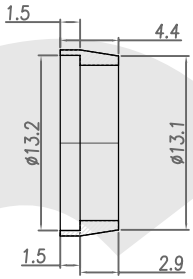
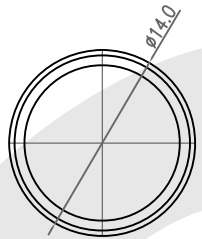

SHELL B

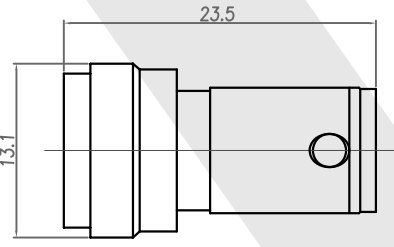
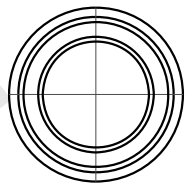

SHELL C

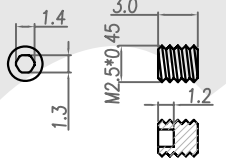

SCREW

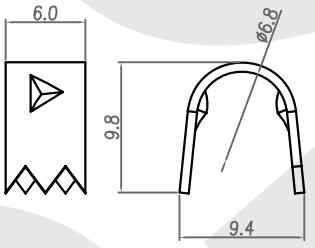

CRAMP

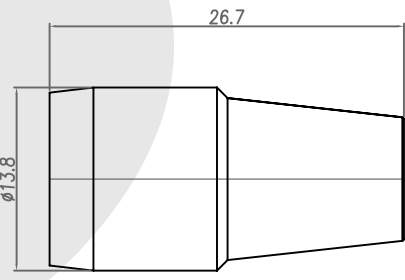
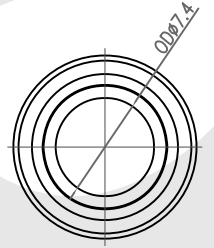

SR

**SST SOUTH SEA TERMINAL CO.,LTD**

SGS Report No.:	Customer:	Part No.:	
		ST1A-11WR-XXP-S	
Title: P-P CONN. Wire Receptacle Solder Type(M)			
Drawn By: Storm.Li	SCALE	SHEET	REV.
Checked By: du	1:1	2/2	A
Approved By: Tony	Third angle Projection		DWG NO.:
	General Dimension Tolerance		QC5611
		Units	TOLERANCE:
		mm	.x ±0.20
			.xx ±0.10
			.xxx ±0.05
			.xxxx ±0.03
			ANGULA ±1°