

Rev	Revisions	Rev.Drawn	Date
A		Du	23/12/09

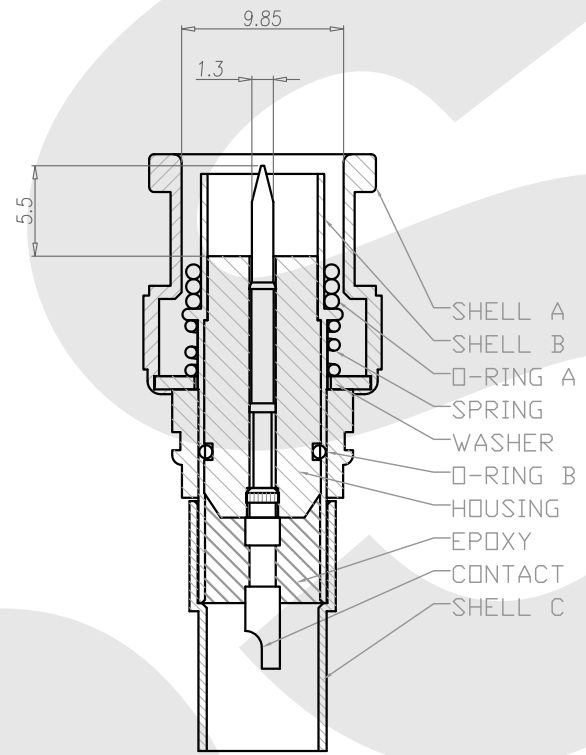
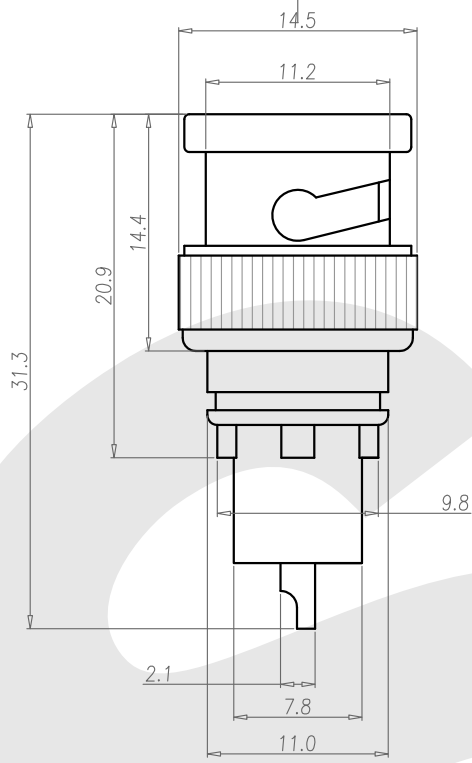
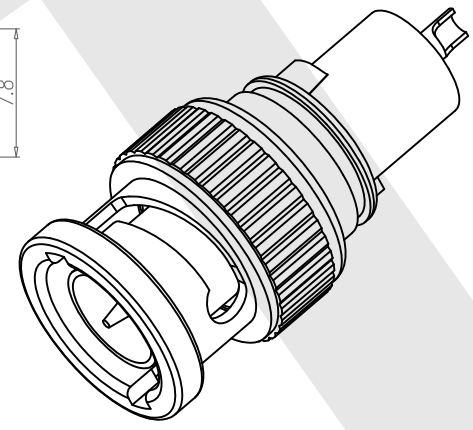
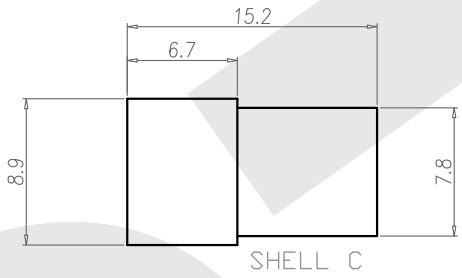
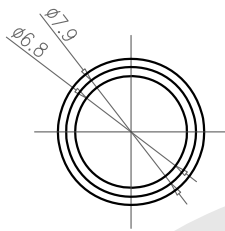
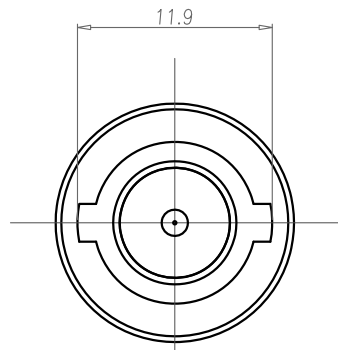

1. MATERIAL :
  - 1-1. HOUSING : TEFLON ; COLOR : WHITE
  - 1-2. CONTACT : BRASS
  - 1-3. SPRING : SPRING STEEL
  - 1-4. O-RING : NBR ; COLOR : WHITE
  - 1-5. SHELL : BRASS
  - 1-6. EPOXY Base :EF400A&EF400B.COLOR:BLACK
  - 1-7. WASHER : BRASS
2. FINISH :
  - 2-1. CONTACT : GOLD FLASH MICRO INCHES MIN.  
UNDER PLATE : NICKEL
  - 2-2. WASHER : NICKEL PLATED
  - 2-3. SHELL : BRIGHT TIN
3. ELECTRICAL SPECIFICATION :
  - 3-1. Rated Voltage : 500 VRMS max.
  - 3-2. IMPEDANCE : 75 Ohm
  - 3-3. Water proof: IP67
4. Environmental :
  - 4-1. Operation Temperature : -40°C~85°C

**SST SOUTH SEA TERMINAL CO.,LTD**

SGS Report No.:	Customer:	Part No.:
		WP-BNC-01-M-W-GF-SNAP
Title: BNC MALE SOLDER TYPE for CABLE (SNAP)		
Drawn By: Storm.Li	SCALE	SHEET
Checked By: du	1:1	1/1
Approved By: Tony	REV.	A
	DWG NO.:	/
Thire angle Projection		Units mm
General Dimesion Tolerance		
TOLERANCE		
.x		±0.20
.xx		±0.10
.xxx		±0.05
.xxxx		±0.03
ANGULA		±1°