

Rev	Revisions	Rev.Drawn	Date
A		Du	23.SEP.2011

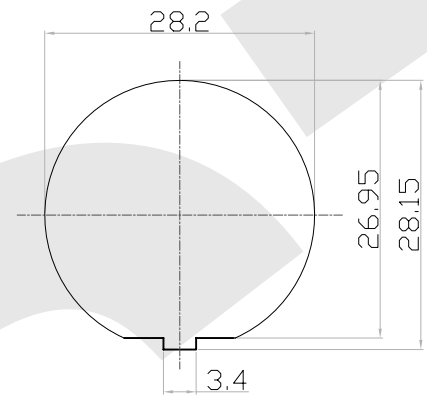

**PANEL CUT-OUT**

- MATERIAL :**
- 1 . USB CONN
  - 1-2 . HOUSING ; PBT UL94V-0 ; COLOR ; BLACK
  - 1-3 . CONTACT ; PHOSPHOR BRONZE
  - 1-4 . SHELL ; BRASS
  - 2 . PARTS
  - 2-1 . EXTERNAL HOUSING ; PBT UL94V-0 ; COLOR ; BLACK
  - 2-2 . NUT ; PBT UL94V-0 ; COLOR ; BLACK
  - 2-3 . WASHER ; PBT UL94V-0 ; COLOR ; BLACK
  - 2-4 . O-RING ; SILICON
  - 3 . PLATING
  - 3-1 . CONTACT ; GOLD PLATING ON CONTACT AREA  
BRIGHT TIN ON SOLDER AREA
  - 3-2 . SHELL ; NICKEL PLATING ON OVER ALL

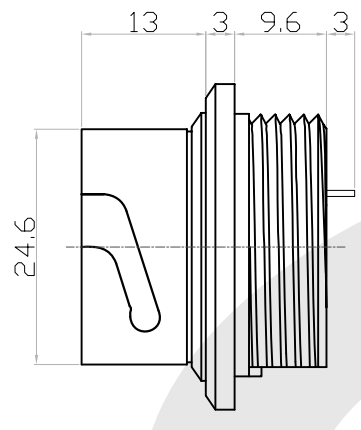
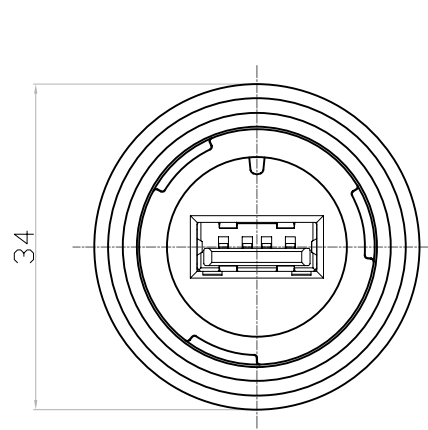
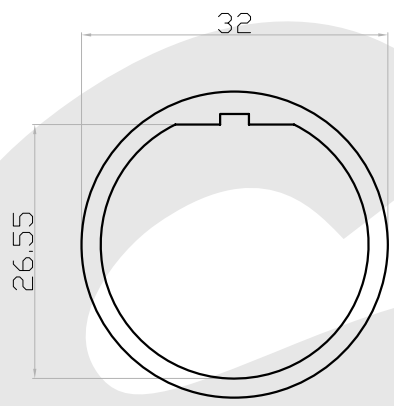

**O-RING**

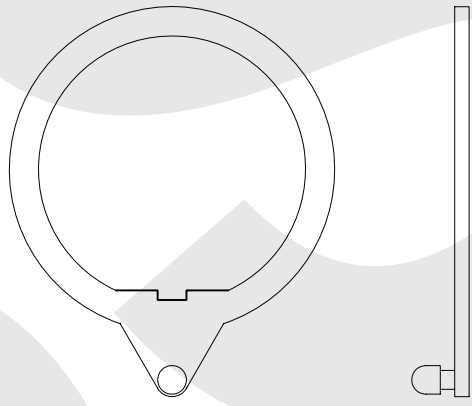
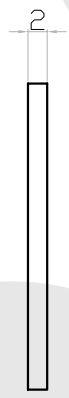

**WASHER**

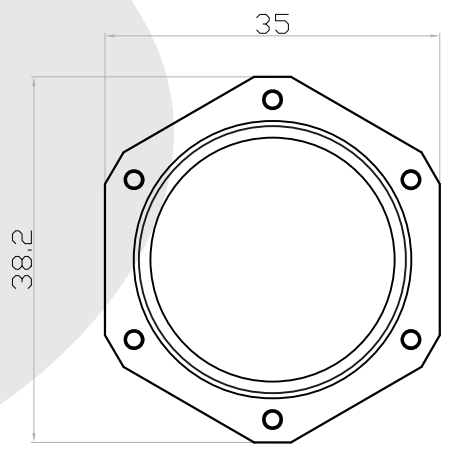

**NUT**

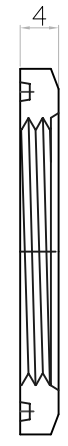

**SST SOUTH SEA TERMINAL CO.,LTD**

SGS Report No.:	Customer:	Part No.:
		WP-USB-04-F-A
Title: 防水USB(F) 鍍金(鍍銀)		
Drawn By: Storm.Li	SCALE	SHEET
Checked By: du	1:1	1/1
Approved By: Tony	REV.	A
	DWG NO.:	QC5534
	Third angle Projection	Units
	General Dimension Tolerance	mm
	TOLERANCE:	
	.x	±0.20
	.xx	±0.10
	.xxx	±0.05
	.xxxx	±0.03
	ANGULA	±1°