

Rev	Revisions	Rev.Drawn	Date
A		Du	22/05/09*

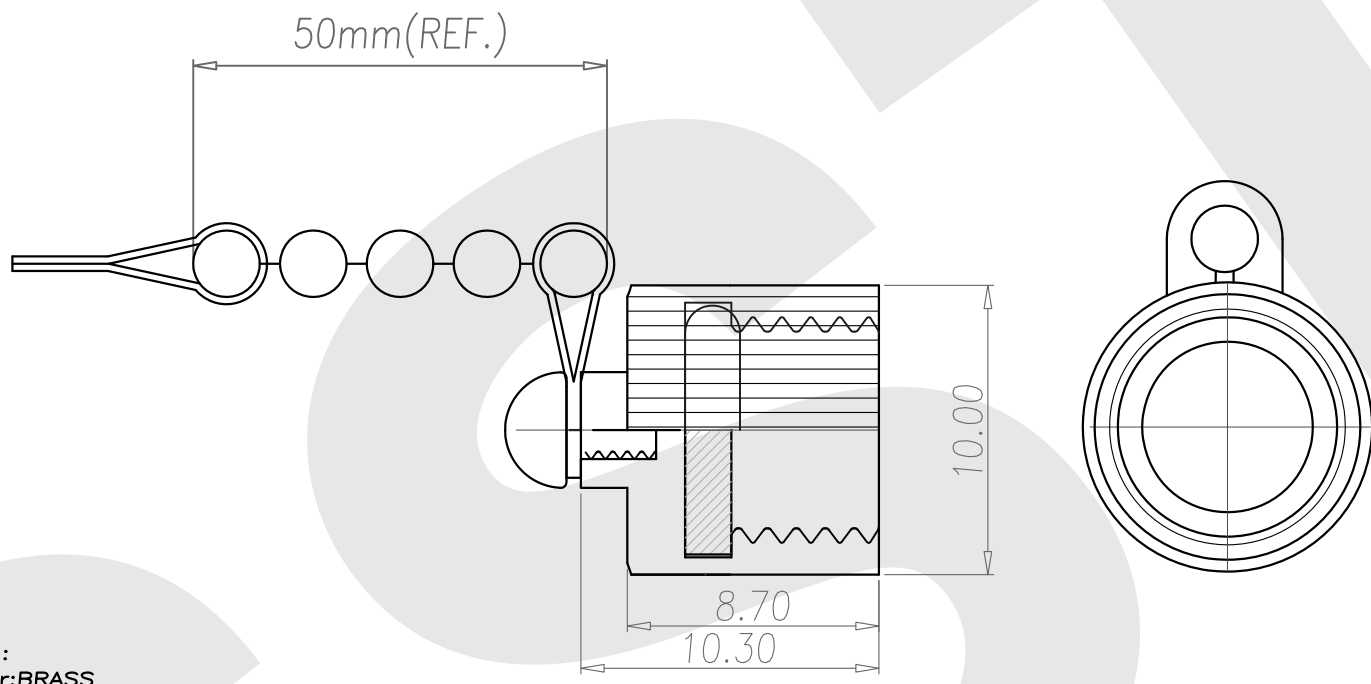

- NOTE:**
1. MATERIAL :
 - 1-1. Cover:BRASS
 - 1-2. SCERW:STEEL
 - 1-3. Snap ring:BRASS
 - 1-4. Bead chain: STEEL
 - 1-5. O-RING:SILICON ; COLOR:BLACK
 2. FINISH :
 - 2-1. COVER: NICKEL PLATED OVER ALL
 - 2-2. SCREW: NICKEL PLATED OVER ALL
 - 2-3. Snap ring: NICKEL PLATED OVER ALL

SST SOUTH SEA TERMINAL CO.,LTD					
SGS Report No.:			Customer:		Part No.:
					8F-M-B-N-OSL-T
Title: M8 FEMALE DUST COVER					
Drawn By: Storm.Li	SCALE	SHEET	REV.	DWG NO.:	TOLERANCE: .x ±0.20 .xx ±0.10 .xxx ±0.05 .xxxx ±0.03 ANGULA ±1*
Checked By: du	1:1	1/1	A	/	
Approved By: Tony	Thire angle Projection		General Dimesion Tolerance		
				Units	mm