

Rev	Revisions	Rev.Drawn	Date
A		Du	30/10/09*

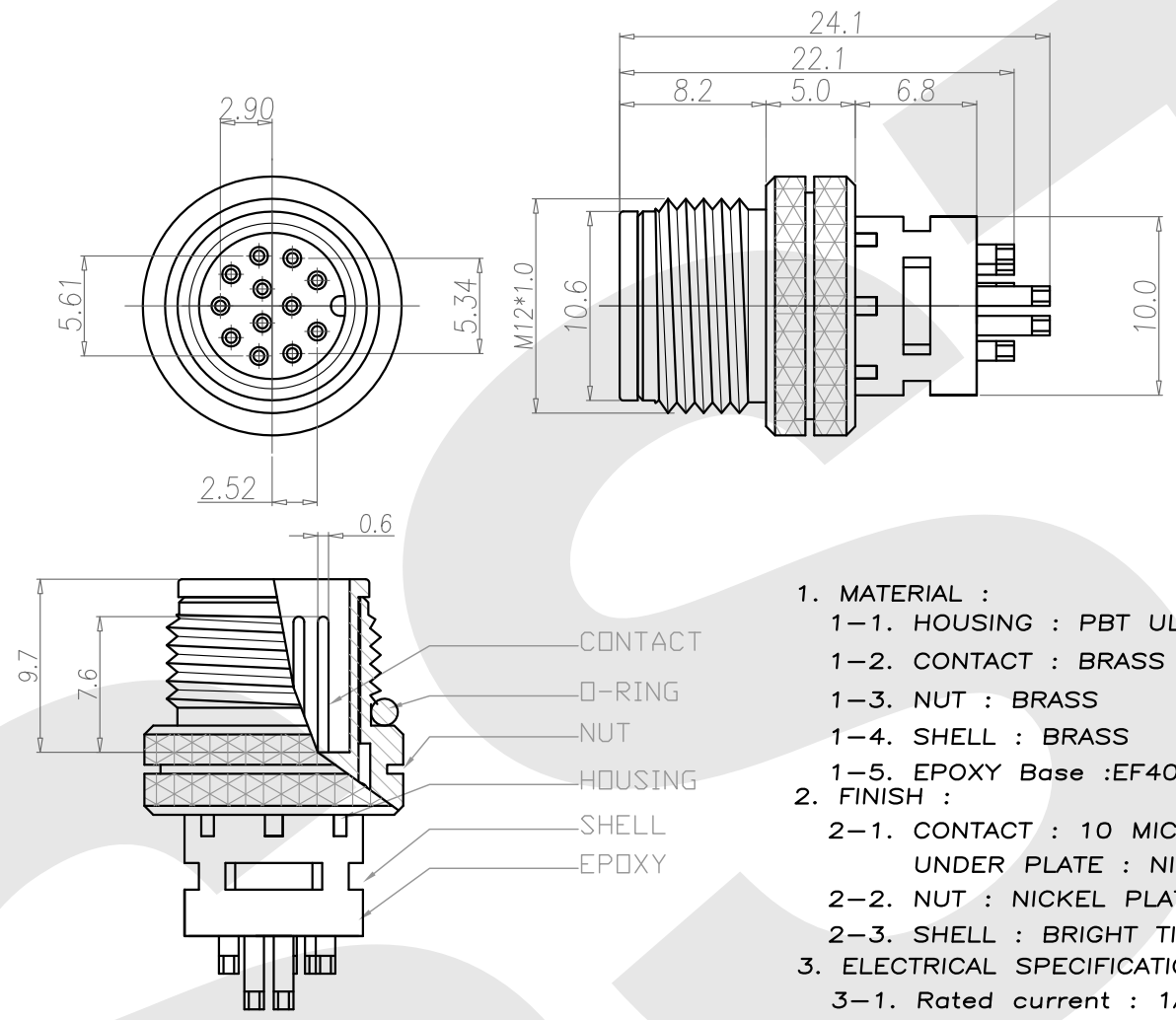

1. MATERIAL :
 - 1-1. HOUSING : PBT UL94V-0 ; COLOR : BLACK
 - 1-2. CONTACT : BRASS
 - 1-3. NUT : BRASS
 - 1-4. SHELL : BRASS
 - 1-5. EPOXY Base :EF400A&EF400B.COLOR:BLACK
2. FINISH :
 - 2-1. CONTACT : 10 MICRO INCHES MIN. GOLD PLATED
UNDER PLATE : NICKEL
 - 2-2. NUT : NICKEL PLATED
 - 2-3. SHELL : BRIGHT TIN
3. ELECTRICAL SPECIFICATION :
 - 3-1. Rated current : 1A
 - 3-2. Rated Voltage : 30V
 - 3-3. Water proof: IPX7
4. Environmental :
 - 4-1. Operation Temperature : -40℃~85℃

CONTACT
O-RING
NUT
HOUSING
SHELL
EPOXY

SST SOUTH SEA TERMINAL CO.,LTD					
SGS Report No.:		Customer:		Part No.:	
				12M12P-W-A-12.2-M-1-G10-B-N-6	
Title: M12 MALE SOLDER TYPE for CABLE (GROUND)					
Drawn By: Storm.Li	SCALE	SHEET	REV.	DWG NO.:	TOLERANCE:
Checked By: du	1:1	1/1	A	/	.x ±0.20 .xx ±0.10 .xxx ±0.05 .xxxx ±0.03 ANGULA ±1*
Approved By: Tony	Thire angle Projection		General Dimesion Tolerance		Units mm