

Rev	Revisions	Rev.Drawn	Date
A		Du	10/02/10"

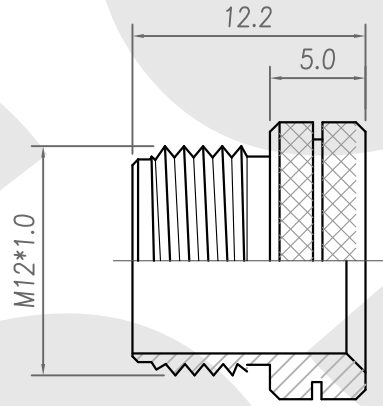
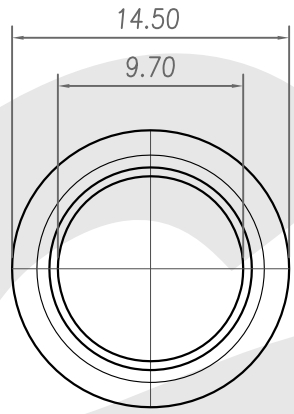
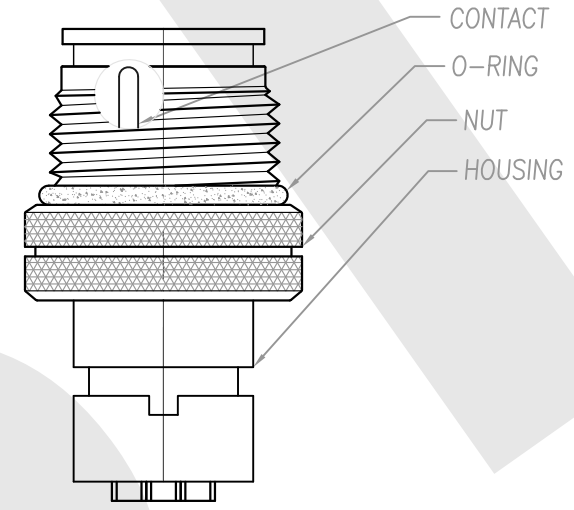
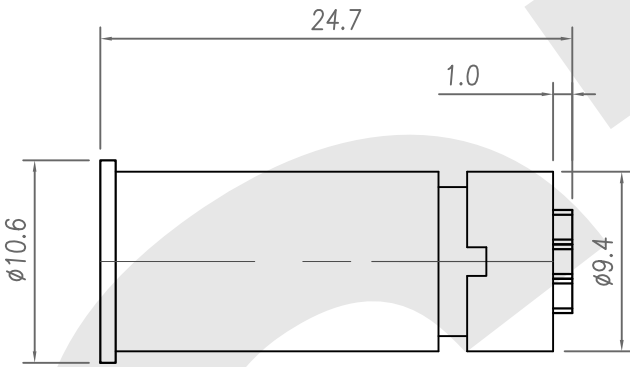
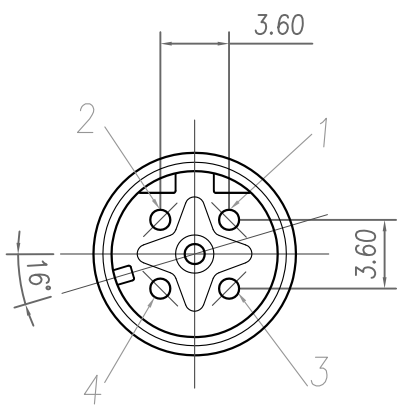

1. MATERIAL :
  - 1-1. HOUSING : PBT UL94V-0 ; COLOR : BLACK
  - 1-2. CONTACT : BRASS
  - 1-3. NUT : BRASS
  - 1-4. O-RING : EPDM ; COLOR : BLACK
2. FINISH :
  - 2-1. CONTACT : 10 MICRO INCHES MIN. GOLD PLATED  
UNDER PLATE : NICKEL
  - 2-2. NUT : NICKEL PLATED 60u" ~ 100u" OVER ALL
3. ELECTRICAL SPECIFICATION :
  - 3-1. Rated current : 5A
  - 3-2. Rated Voltage :125V
  - 3-3. Water proof: IPX7
4. Environmental :
  - 4-1. Operation Temperature : -20°C~85°C

**SST** SOUTH SEA TERMINAL CO.,LTD

SGS Report No.:	Customer:	Part No.:
	12MSP-W-D-12.2-P-2-G10-B-N	
Title:M12 MALE SOLDER TYPE for CABLE (D CODE)		
Drawn By:Storm.Li	SCALE	SHEET
Checked By:du	1:1	1/1
Approved By: Tony	REV.	A
	DWG NO.:	/
	TOLERANCE:	
	.x ±0.20	
	.xx ±0.10	
	.xxx ±0.05	
	.xxxx ±0.03	
	ANGULA ±1*	
	Thire angle Projection	Units
	General Dimension Tolerance	mm