

Rev	Revisions	Rev.Drawn	Date
A		Du	20,OCT.2011

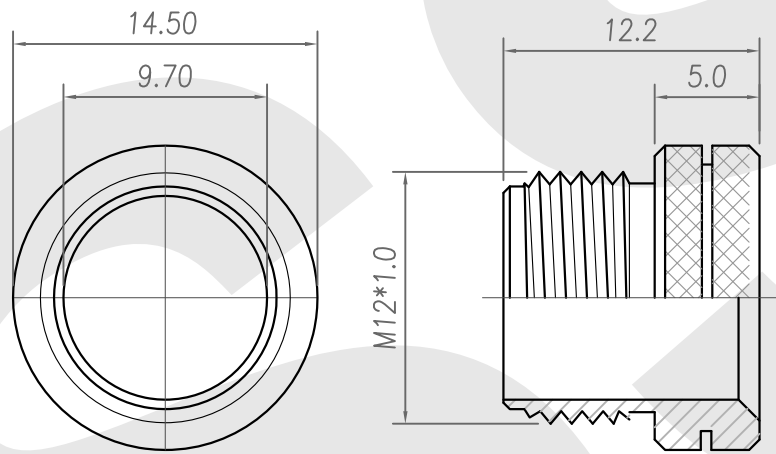
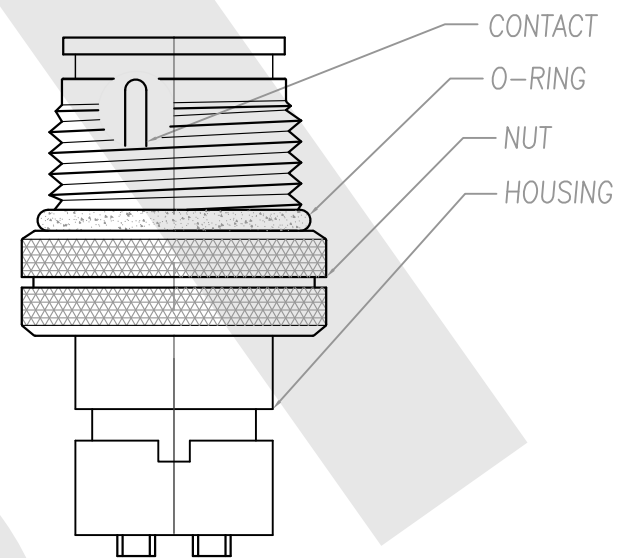
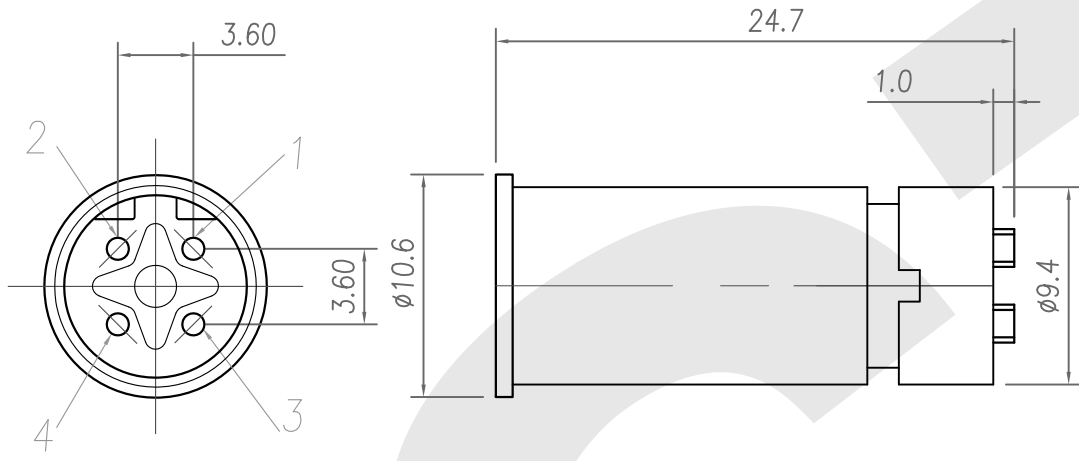

1. MATERIAL :
 - 1-1. HOUSING : PBT UL94V-0 ; COLOR : BLACK
 - 1-2. CONTACT : BRASS
 - 1-3. NUT : BRASS
 - 1-4. O-RING : EPDM
2. FINISH :
 - 2-1. CONTACT : 10 MICRO INCHES MIN. GOLD PLATED
UNDER PLATE : NICKEL
 - 2-2. NUT : NICKEL PLATED 60u" ~ 100u" OVER ALL
3. ELECTRICAL SPECIFICATION :
 - 3-1. Rated current : 5A
 - 3-2. Rated Voltage :125V
 - 3-3. Water proof: IPX7
4. Environmental :
 - 4-1. Operation Temperature : -20C~85C

SST SOUTH SEA TERMINAL CO.,LTD

SGS Report No.: Customer: Part No.: 12M4P-W-B-12.2-P-2-G10-B-N

Title: M12 MALE SOLDER TYPE for CABLE (B CODE)

Drawn By: Storm.Li	SCALE	SHEET	REV.	DWG NO.:	TOLERANCE .x ±0.20 .xx ±0.10 .xxx ±0.05 .xxxx ±0.03 ANGULA ±1°
Checked By: du	1:1	1/1	A	SST-111020-01	
Approved By: Tony	Third angle Projection			Units mm	
	General Dimension Tolerance				