

Rev	Revisions	Rev.Drawn	Date
A		Du	31,May,2011

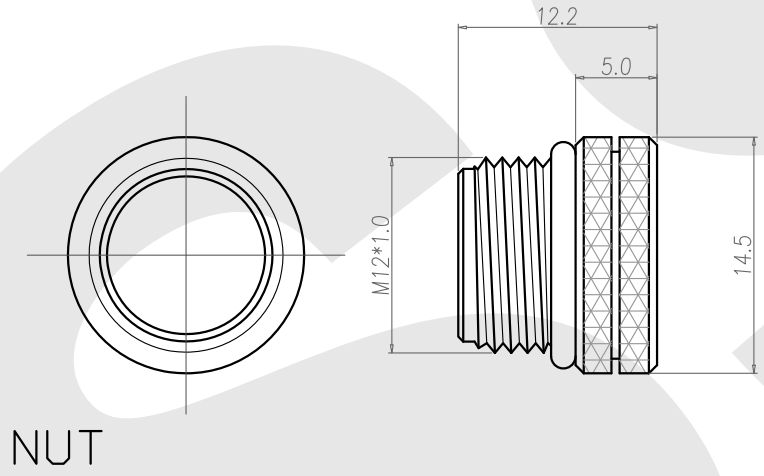
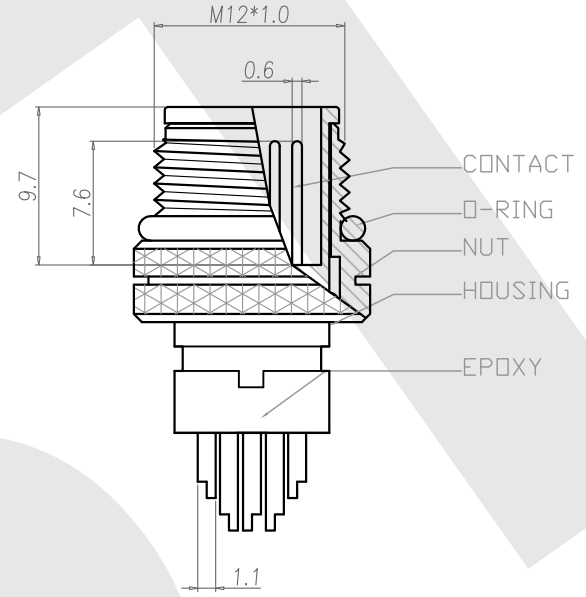
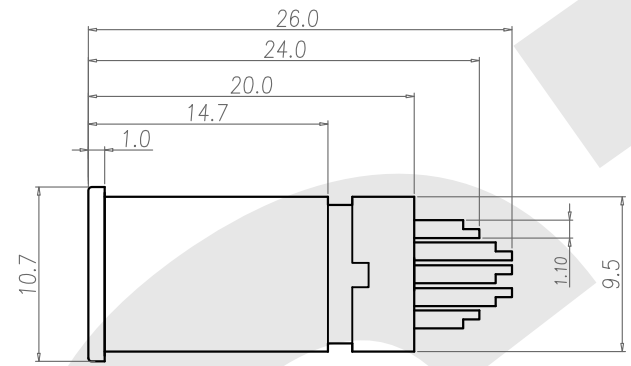
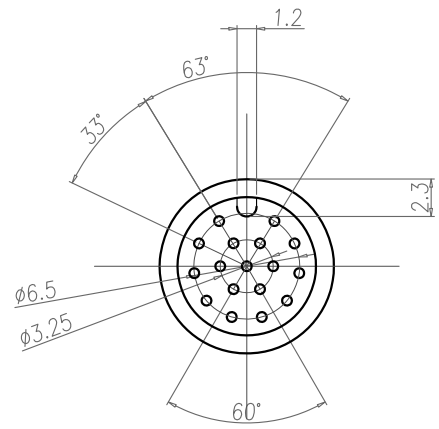

1. MATERIAL :
  - 1-1. HOUSING : PBT UL94V-0 ; COLOR : BLACK
  - 1-2. CONTACT : BRASS
  - 1-3. NUT : BRASS
  - 1-4. O-RING : EDPM ; COLOR : BLACK
  - 1-5. EPOXY Base :EF400A&EF400B.COLOR:BLACK
2. FINISH :
  - 2-1. CONTACT : 10 MICRO INCHES MIN. GOLD PLATED  
UNDER PLATE : NICKEL
  - 2-2. NUT : NICKEL PLATED
3. ELECTRICAL SPECIFICATION :
  - 3-1. Rated current : 1A
  - 3-2. Rated Voltage : 30V
  - 3-3. Water proof: IPX7
4. Environmental :
  - 4-1. Operation Temperature : -40℃~85℃

**SST** SOUTH SEA TERMINAL CO.,LTD

SGS Report No.:	Customer:	Part No.:
		12M17P-W-A-12.2-P-2-G10-B-N-3
Title: M12 MALE SOLDER TYPE for CABLE		
Drawn By: Storm.Li	SCALE	SHEET
Checked By: du	1:1	1/1
Approved By: Tony	Thire angle Projection	REV. A
	General Dimesion Tolerance	DWG NO.:
		SST-110531-13
		Units
		mm
		TOLERANCE
		.x ±0.20
		.xx ±0.10
		.xxx ±0.05
		.xxxx ±0.03
		ANGULA ±1°