

Rev	Revisions	Rev.Drawn	Date
A		Du	04/08/09*

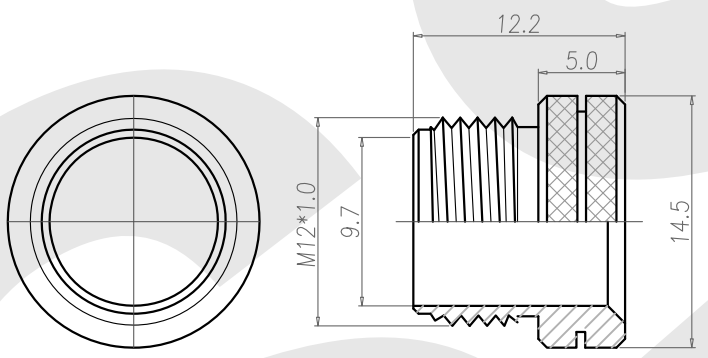
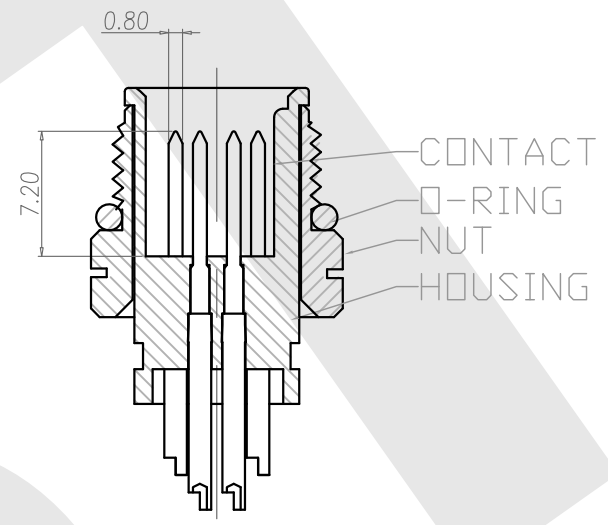
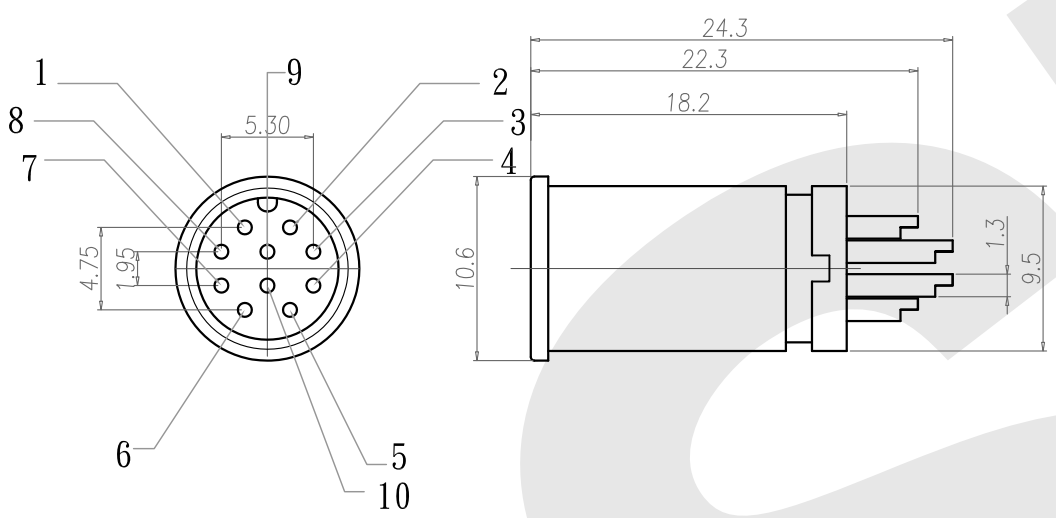

NUT

1. MATERIAL :
 - 1-1. HOUSING : PBT UL94V-0 ; COLOR : BLACK
 - 1-2. CONTACT : BRASS
 - 1-3. NUT : BRASS
 - 1-4. O-RING : EPDM
2. FINISH :
 - 2-1. CONTACT : 10 MICRO INCHES MIN. GOLD PLATED
UNDER PLATE : NICKEL
 - 2-2. NUT : NICKEL PLATED
3. ELECTRICAL SPECIFICATION :
 - 3-1. Rated current : 5A
 - 3-2. Rated Voltage : 125V
 - 3-3. Water proof: IPX7
4. Environmental :
 - 4-1. Operation Temperature : -40℃~85℃

SST SOUTH SEA TERMINAL CO.,LTD						
SGS Report No.:		Customer:		Part No.:		
				12M10P-W-A-12.2-P-2-G10-B-N-2		
Title:M12 MALE SOLDER TYPE for CABLE						
Drawn By:Storm.Li	SCALE	SHEET	REV.	DWG NO.:		TOLERANCE:
Checked By:du	1:1	1/1	A	/		.x ±0.20
Approved By: Tony	Thire angle Projection			Units		.xxx ±0.10
	General Dimesion Tolerance					mm
						ANGULA ±1*