

Rev	Revisions	Rev.Drawn	Date
A		Du	25.11.2008

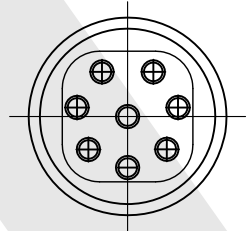

1. MATERIAL :
 - 1-1. HOUSING : PBT UL94V-0;COLOR: BLACK
 - 1-2. CONTACT : BRASS
 - 1-3. NUT : BRASS
 - 1-4. O-RING : EPDM ; COLOR : BLACK
 - 1-5. Epoxy Base :EF400A&EF400B.COLOR:BLACK
2. FINISH :
 - 2-1. CONTACT A : 10 MICRO INCHES MIN. GOLD PLATED
UNDER PLATE : NICKEL
 - 2-2. NUT : NICKEL PLATED 60u" ~ 100u" OVER ALL
3. ELECTRICAL SPECIFICATION :
 - 3-1. Rated current : 5A
 - 3-2. Voltage :125V
 - 3-3. Water proof: IPX7
4. Environmental :
 - 4-1. Operation Temperature : -40 ℃~85℃

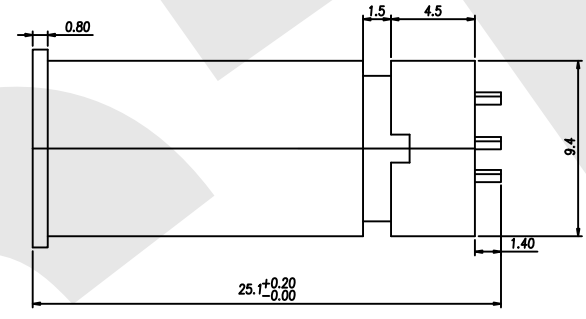
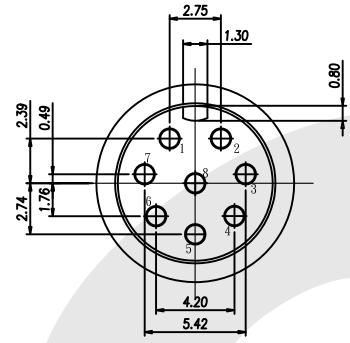
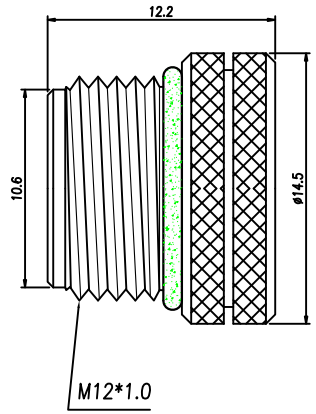
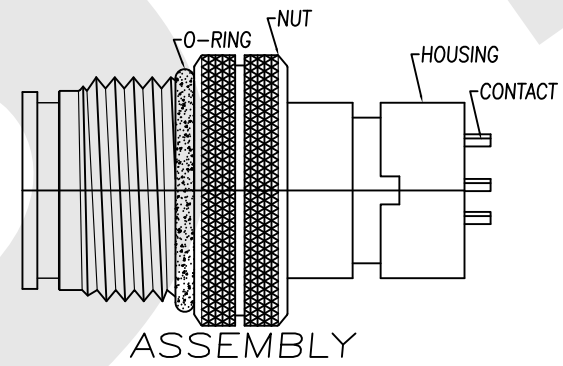

ASSEMBLY

SST SOUTH SEA TERMINAL CO.,LTD

SGS Report No.:	Customer:	Part No.:
		12MBP-W-A-12.2-P-2-G10-B-N-2
Title: M12 MALE SOLDER TYPE for CABLE		
Drawn By: Storm.Li	SCALE	SHEET
Checked By: du	1:1	1/1
Approved By: Tony	REV.	A
	DWG NO.:	SST-081125-01
	TOLERANCE:	
	X. ±2MM	
	.X ±0.25MM	
	.XX ±0.1MM	
	.XXX±0.1MM	
	Third angle Projection	Units
	General Dimension Tolerance	mm