

Rev	Revisions	Rev.Drawn	Date
A		Du	05/07/10*

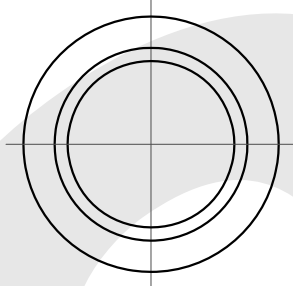

NUT

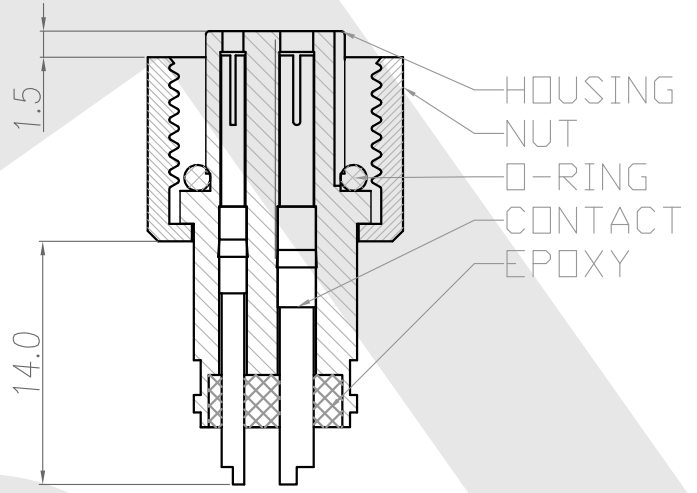
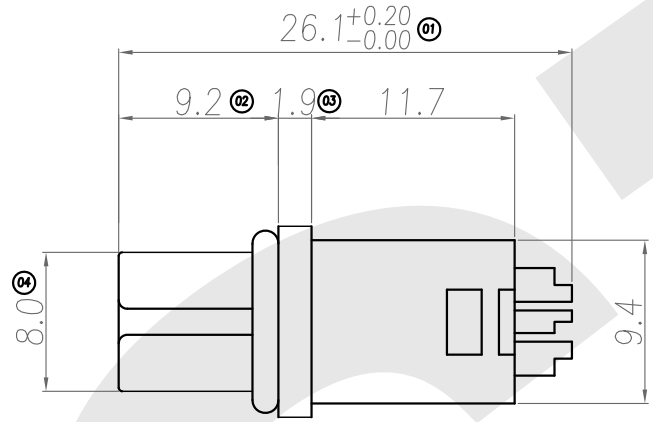
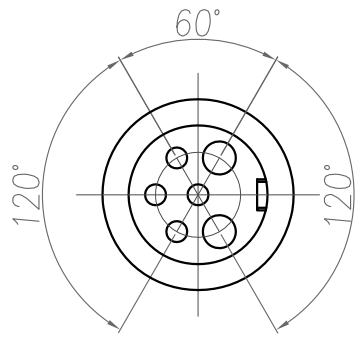
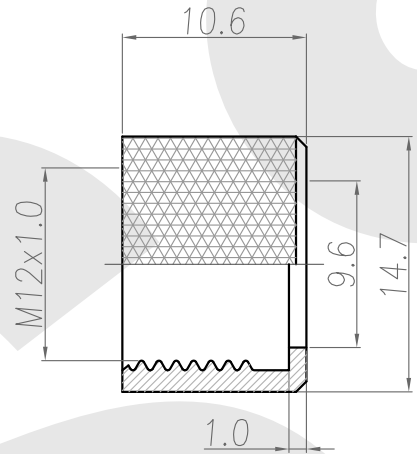

12F2+4P-W-A-10.6-P-2-GF-B-N-3	12F2P-W-A-10.6-P-2-GF-B-N-3

1. MATERIAL :
  - 1-1. HOUSING : PBT UL94V-0 ; COLOR : BLACK.
  - 1-2. CONTACT : BRASS
  - 1-3. NUT : BRASS
  - 1-4. O-RING : EPDM ; COLOR : BLACK
  - 1-5. Epoxy Base : EF400A&EF400B. COLOR : BLACK.
2. FINISH :
  - 2-1. CONTACT : GOLD FLASH MICRO INCHES MIN.  
UNDER PLATE : NICKEL
  - 2-2. NUT : NICKEL PLATED.
3. ELECTRICAL SPECIFICATION :
  - 3-1. Rated current : 3A+10A
  - 3-2. Rated Voltage : 125V
  - 3-3. Water proof : IPX7
4. Environmental :
  - 4-1. Operation Temperature : -40 °C~85°C

**SST SOUTH SEA TERMINAL CO.,LTD**

SGS Report No.:	Customer:	Part No.:
		12F2+4P-W-A-10.6-P-2-GF-B-N-3
Title:M12 FEMALE SOLDER TYPE for CABLE (10A,10A+3A)		
Drawn By:Storm.Li	SCALE	SHEET
Checked By:du	1:1	1/1
Approved By: Tony	REV.	A
	DWG NO.:	/
	Units	mm
	TOLERANCE:	.x ±0.20
		.xx ±0.10
		.xxx ±0.05
		.xxxx ±0.03
		ANGULA ±1*