

Rev	Revisions	Rev.Drawn	Date
A		Du	31,May,2011

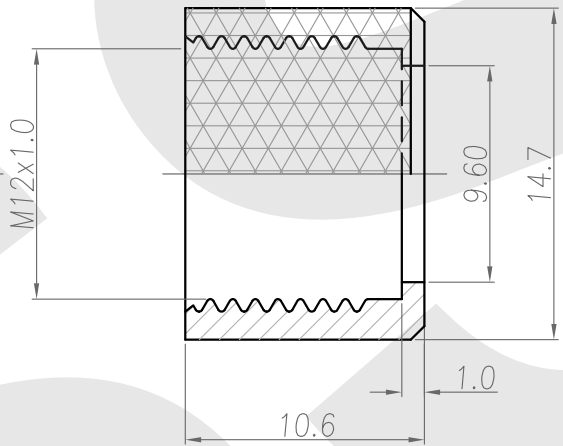
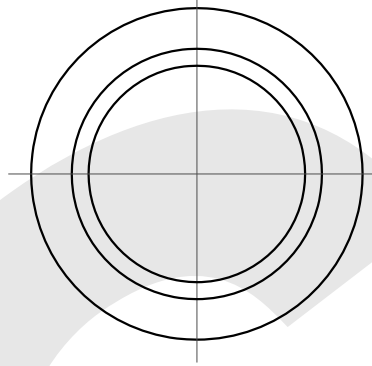
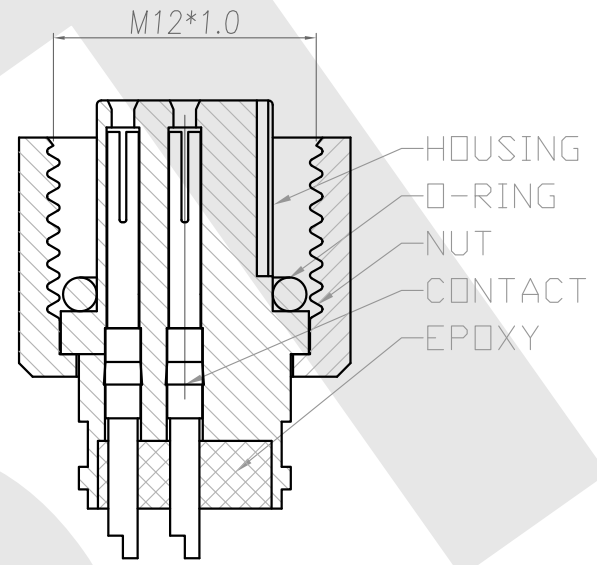
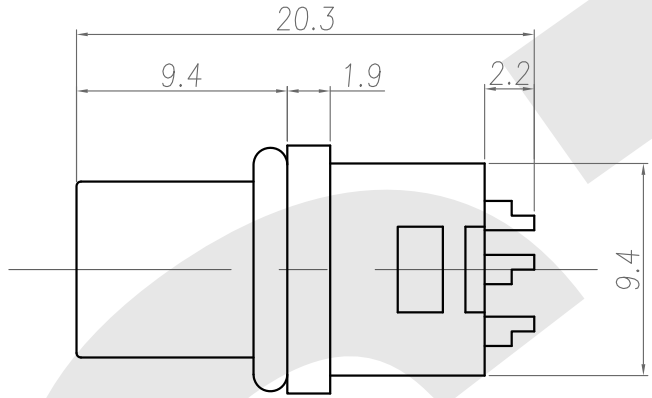
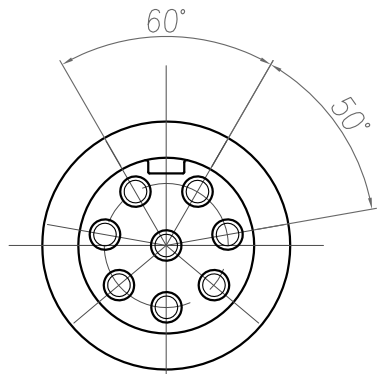

NUT

1. MATERIAL :
 - 1-1. HOUSING : PBT UL94V-0 ; COLOR : BLACK
 - 1-2. CONTACT : BRASS
 - 1-3. NUT : BRASS
 - 1-4. O-RING :EPDM; COLOR : BLACK
2. FINISH :
 - 2-1. CONTACT : 10 MICRO INCHES MIN. GOLD PLATED
UNDER PLATE : NICKEL
 - 2-2. NUT : NICKEL PLATED.
3. ELECTRICAL SPECIFICATION :
 - 3-1. Rated current : 5A
 - 3-2. Rated Voltage :125V
 - 3-3. Water proof: IPX7
4. Environmental :
 - 4-1. Operation Temperature : -40℃~85℃

SST SOUTH SEA TERMINAL CO.,LTD

SGS Report No.:	Customer:	Part No.:
		12FBP-W-A-10.6-P-2-G10-B-N-4
Title: M12 FEMALE SOLDER TYPE for CABLE		
Drawn By: Storm.Li	SCALE	SHEET
Checked By: du	1:1	1/1
Approved By: Tony	Thire angle Projection	REV. A
	General Dimesion Tolerance	DWG NO.:
		SST-110531-08
		Units
		mm
		TOLERANCE
		.x ±0.20
		.xx ±0.10
		.xxx ±0.05
		.xxxx ±0.03
		ANGULA ±1°