

Rev	Revisions	Rev.Drawn	Date
A		Du	11/12/09*

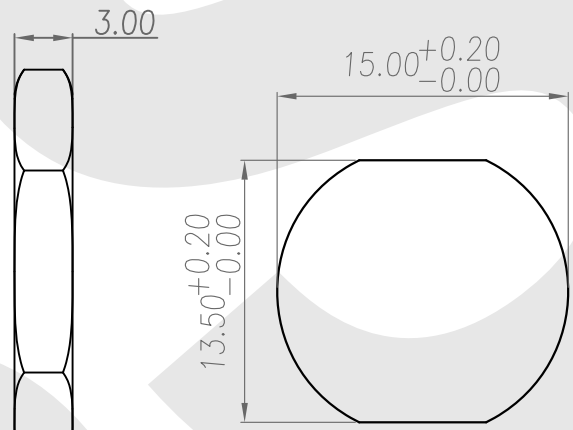
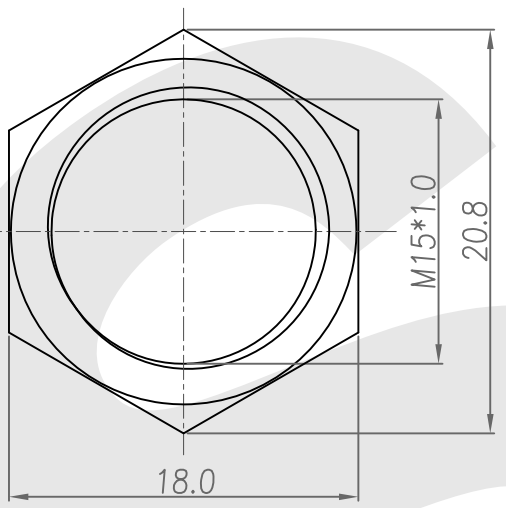
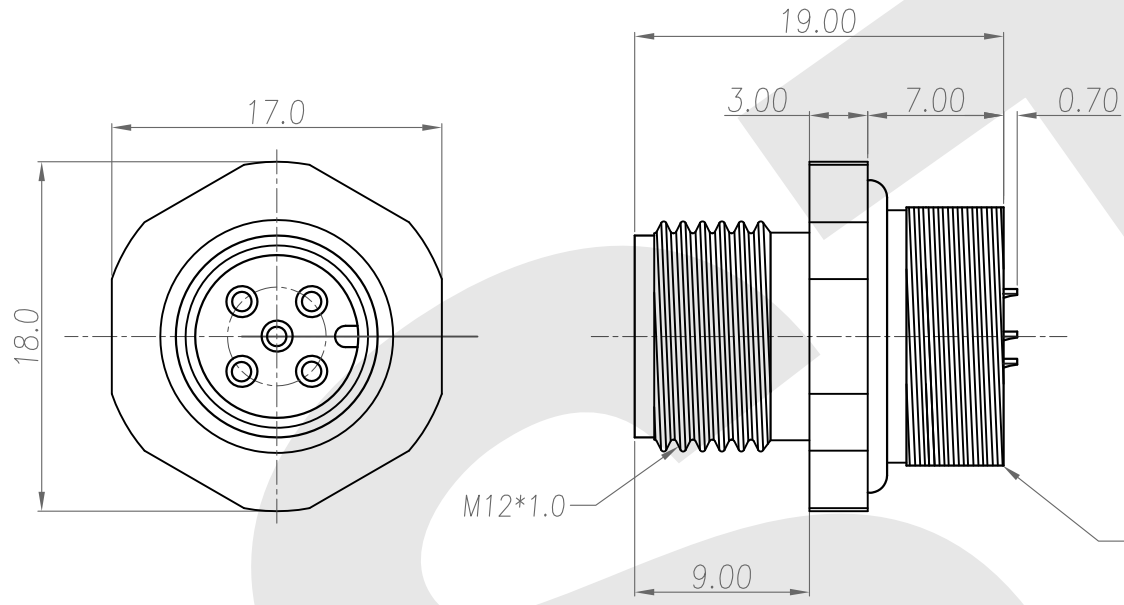

1. MATERIAL :
  - 1-1. HOUSING : PBT UL94V-0 ; COLOR : BLACK
  - 1-2. CONTACT : BRASS
  - 1-3. NUT : BRASS
  - 1-4. O-RING : EPDM ; COLOR : BLACK △
2. FINISH :
  - 2-1. CONTACT A : 10 MICRO INCHES MIN. GOLD PLATED  
UNDER PLATE : NICKEL
  - 2-2. NUT : NICKEL PLATED OVER ALL
3. ELECTRICAL SPECIFICATION :
  - 3-1. Rated current : 5A
  - 3-2. Voltage :125V
  - 3-3. Water proof: IPX7
4. Environmental :
  - 4-1. Operation Temperature : -40℃~85℃

**SST SOUTH SEA TERMINAL CO.,LTD**

SGS Report No.:	Customer:	Part No.:			
	12M5P-B-A-BL-15x1.0-D-S-G10-B-N-1				
Title:M12 MALE SOLDER TYPE BACK LOCK for PANEL (M15)					
Drawn By:Storm.Li	SCALE	SHEET	REV.	DWG NO.:	TOLERANCE: .x ±0.20 .xx ±0.10 .xxx ±0.05 .xxxx ±0.03 ANGULA ±1°
Checked By:du	1:1	1/1	A	/	
Approved By: Tony	Thire angle Projection		General Dimesion Tolerance		Units mm