

| | | | |
|-----|-----------|-----------|-------------|
| Rev | Revisions | Rev.Drawn | Date |
| A | | Du | 02.Apr.2013 |

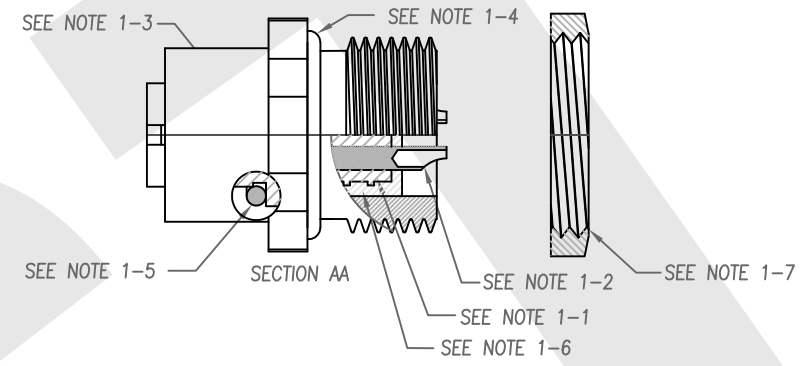
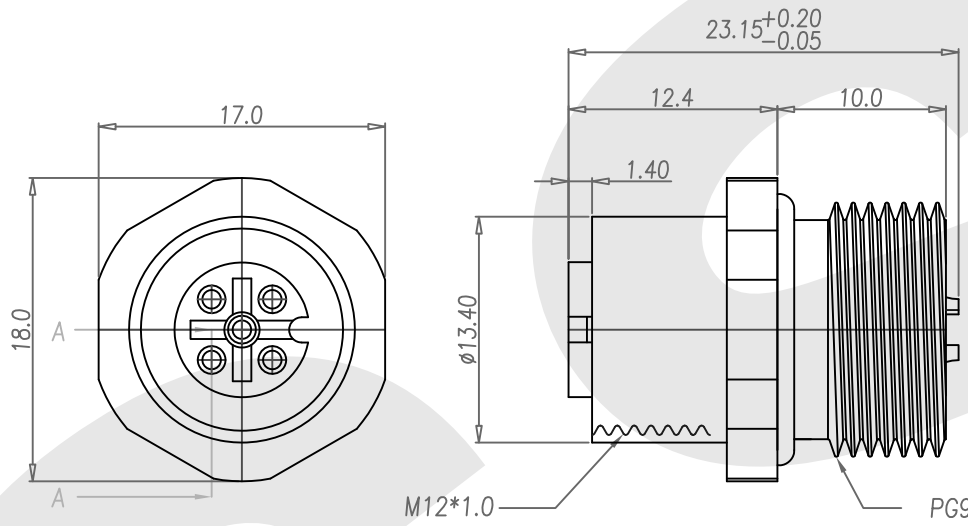

- NOTE
- MATERIAL
 - 1-1.INSULATION: THERMOPLASTIC UL94V-0
COLOR: BLACK.
 - 1-2.CONTACT: BRASS ;CONTACT PLATED GOLD 10u"
AER Nickel
 - 1-3.SHELL: BRASS ;PLATED Nickel
 - 1-4.0-RingA: NBR COLOR: BLACK.
 - 1-5.0-RingB: EPDM COLOR: BLACK.
 - 1-6.Epoxy Base :EF400A&EF400B.
COLOR:BLACK
 - 1-7.NUT : BRASS ;PLATED Nickel

SST SOUTH SEA TERMINAL CO.,LTD

| | | |
|--|--------------------------------|-----------|
| SGS Report No.: | Customer: | Part No.: |
| | 12F5P-B-A-BL-PG9-C-S-G10-B-N-1 | |
| Title:M12 FEMALE SOLDER TYPE BACK LOCK for PANEL (PG9) | | |
| Drawn By:Storm.Li | SCALE | SHEET |
| Checked By:du | 1:1 | 1/1 |
| Approved By: Tony | REV. | A |
| | DWG NO.: | / |
| | Thire angle Projection | Units |
| | General Dimension Tolerance | mm |
| | TOLERANCE: | |
| | .x | ±0.20 |
| | .xx | ±0.10 |
| | .xxx | ±0.05 |
| | .xxxx | ±0.03 |
| | ANGULA | ±1° |