

Rev	Revisions	Rev.Drawn	Date
A		Du	25.11.2008

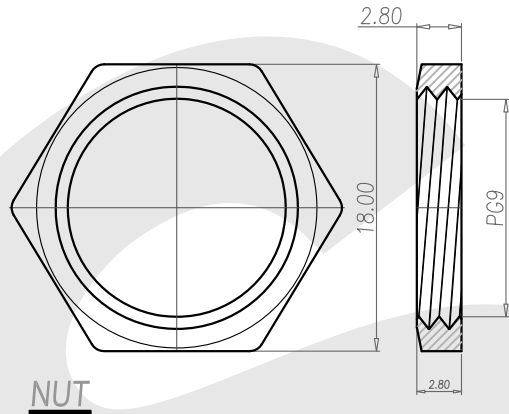

NUT

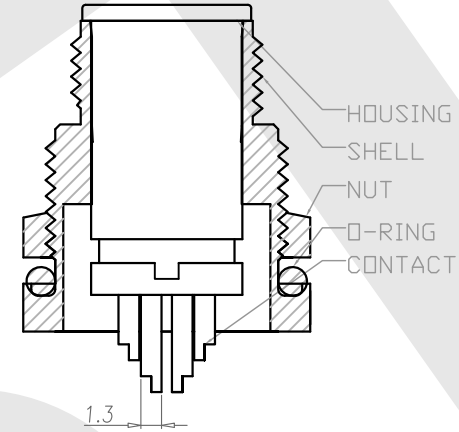
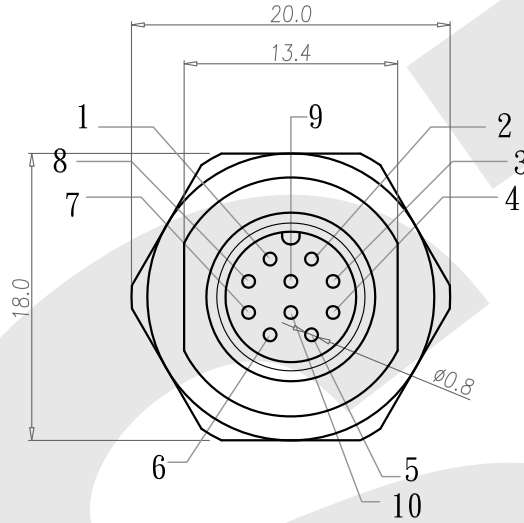
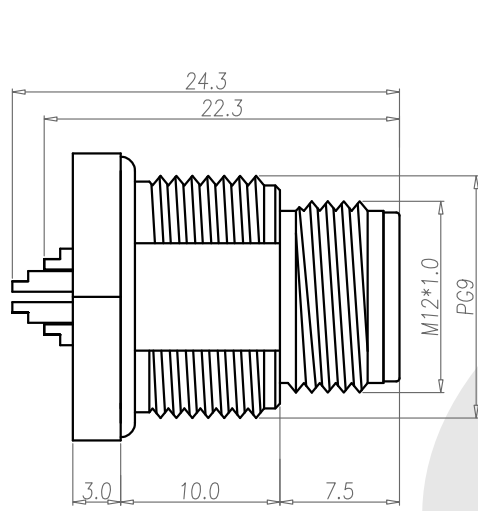
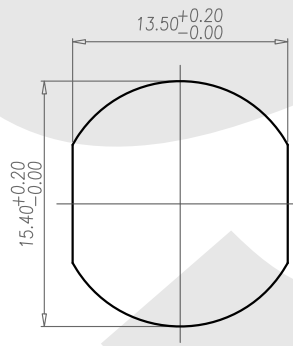

RECOMMEND PANEL CUT-OUT

1. MATERIAL :
 - 1-1. HOUSING : PBT UL94V-0 ; COLOR : BLACK
 - 1-2. CONTACT : BRASS
 - 1-3. NUT : BRASS
 - 1-4. SHELL : BRASS
 - 1-5. O-RING : EPDM COLOR : BLACK
2. FINISH :
 - 2-1. CONTACT : 10 MICRO INCHES MIN. GOLD PLATED
UNDER PLATE : NICKEL
 - 2-2. NUT : NICKEL PLATED
 - 2-3. SHELL : NICKEL PLATED
3. ELECTRICAL SPECIFICATION :
 - 3-1. Rated current : 5A
 - 3-2. Rated Voltage : 125V
 - 3-3. Water proof: IPX7
4. Environmental :
 - 4-1. Operation Temperature : -40℃~85℃

SST SOUTH SEA TERMINAL CO.,LTD

SGS Report No.:	Customer:	Part No.:
	12M10P-B-A-FL-PG9-D-S-G10-B-N-3	
Title: M12 MALE SOLDER TYPE FRONT LOCK for PANEL(PG9)		
Drawn By: Storm.Li	SCALE: 1:1	SHEET: 1/1
Checked By: du	REV: A	DWG NO.: SST-081125-01
Approved By: Tony	TOLERANCE: X. ±2MM .X ±0.25MM .XX ±0.1MM .XXX±0.1MM	
Thire angle Projection		Units: mm
General Dimension Tolerance		