

Rev	Revisions	Rev.Drawn	Date
A		Du	04/03/13*

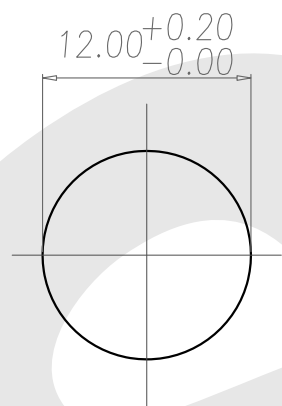

RECOMMEND PANEL CUT-OUT

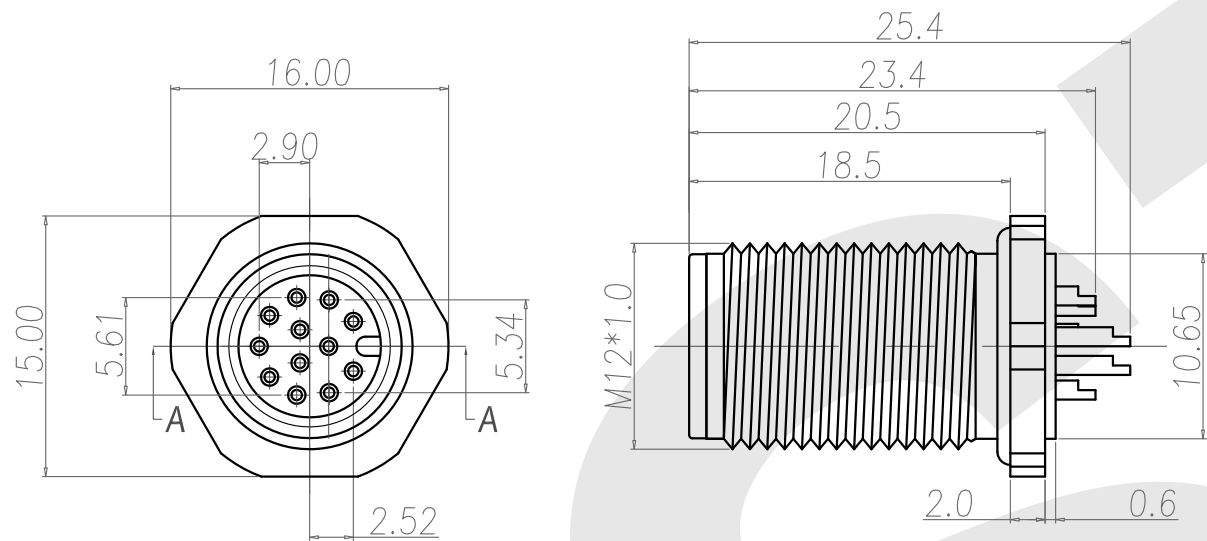
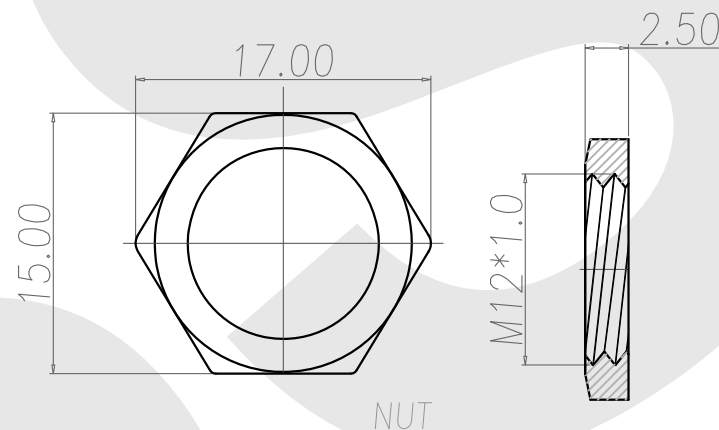

NUT

1. MATERIAL :
 - 1-1. HOUSING : PBT UL94V-0 ; COLOR : BLACK
 - 1-2. CONTACT : BRASS
 - 1-3. NUT : BRASS
 - 1-4. SHELL : BRASS
 - 1-5. O-RING : EDPM
2. FINISH :
 - 2-1. CONTACT : 10 MICRO INCHES MIN. GOLD PLATED
UNDER PLATE : NICKEL
 - 2-2. NUT : NICKEL PLATED
 - 2-3. SHELL : NICKEL PLATED
3. ELECTRICAL SPECIFICATION :
 - 3-1. Rated current : 1A
 - 3-2. Rated Voltage : 30V
 - 3-3. Water proof: IPX7
4. Environmental :
 - 4-1. Operation Temperature : -40°C~85°C

SST SOUTH SEA TERMINAL CO.,LTD

SGS Report No.:	Customer:	Part No.:		
		12M12P-B-A-FL-12x1.0-C-S-G10-B-N-3		
Title: M12 MALE SOLDER TYPE FRONT LOCK for PANEL				
Drawn By: Storm.Li	SCALE	SHEET	REV.	DWG NO.:
Checked By: du	1:1	1/1	A	/
Approved By: Tony	Thire angle Projection		Units	
General Dimension Tolerance		mm		TOLERANCE:
				.x ±0.20
				.xx ±0.10
				.xxx ±0.05
				.xxxx ±0.03
				ANGULA ±1*