

Rev	Revisions	Rev.Drawn	Date
A		Du	02/04/10"

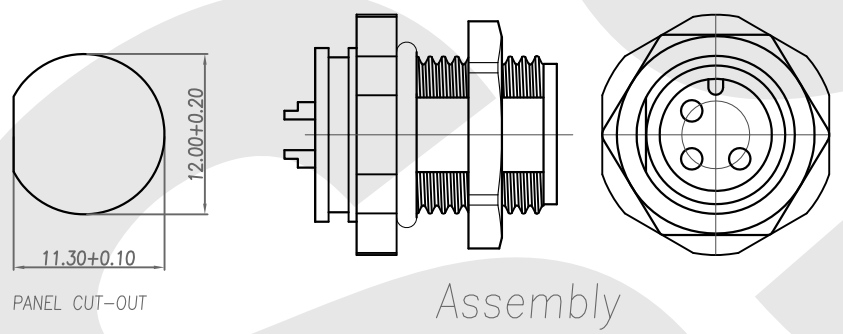
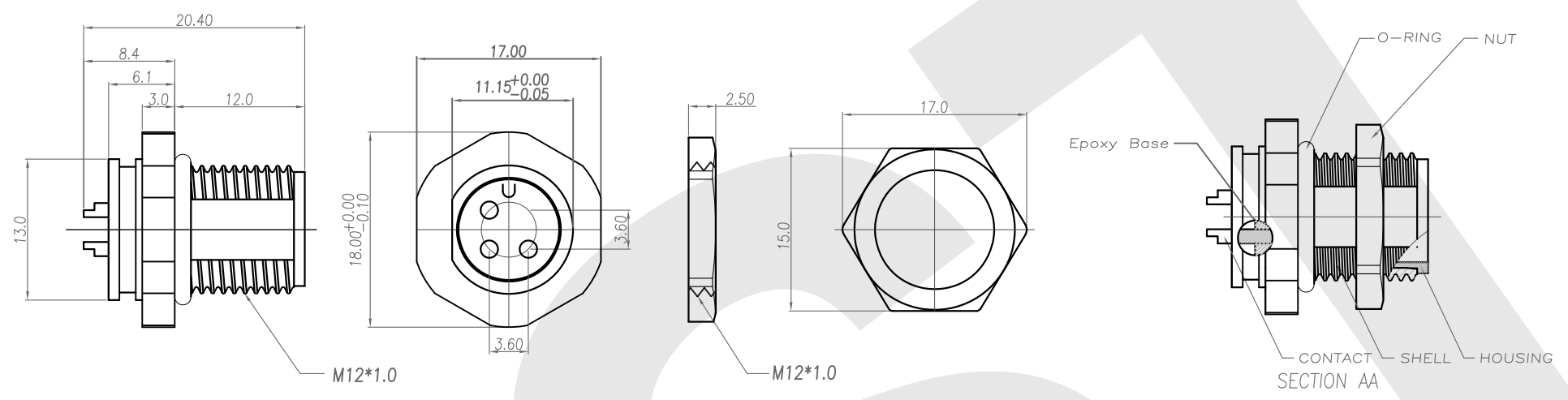

1. MATERIAL :
 - 1-1. HOUSING : PBT UL94V-0 ; COLOR : BLACK
 - 1-2. CONTACT : COPPER ALLOY
 - 1-3. SHELL : COPPER ALLOY
 - 1-4. NUT : COPPER ALLOY
 - 1-5. O-RING : EPDM ; COLOR : BLACK
 - 1-6. Epoxy Base :EF400A&EF400B. COLOR:BLACK
2. FINISH :
 - 2-1. CONTACT :10 MICRO INCHES MIN. GOLD PLATING OVER NICKEL
 - 2-2. SHELL : NICKEL PLATED 60u" ~ 100u" OVER ALL
 - 2-3. NUT : NICKEL PLATED 60u" ~ 100u" OVER ALL
3. ELECTRICAL SPECIFICATION :
 - 3-1. Rated current : 5A
 - 3-2. Voltage :125V
 - 3-3. Water proof: IPX7
4. Environmental :
 - 4-1. Operation Temperature : -40 ℃~85℃

SST SOUTH SEA TERMINAL CO.,LTD

SGS Report No.:	Customer:	Part No.:
		12M3P-B-A-FL-12x1.0-S-S-G10-B-N-2
Title:M12 MALE SOLDER TYPE FRONT LOCK for PANEL		
Drawn By:Storm.Li	SCALE	SHEET
Checked By:du	1:1	1/1
Approved By: Tony	REV.	A
	DWG NO.:	/
	Third angle Projection	Units
	General Dimension Tolerance	mm
	TOLERANCE:	
	.x ±0.20	
	.xx ±0.10	
	.xxx ±0.05	
	.xxxx ±0.03	
	ANGULA ±1*	