

Rev	Revisions	Rev.Drawn	Date
A		Du	17/01/13"

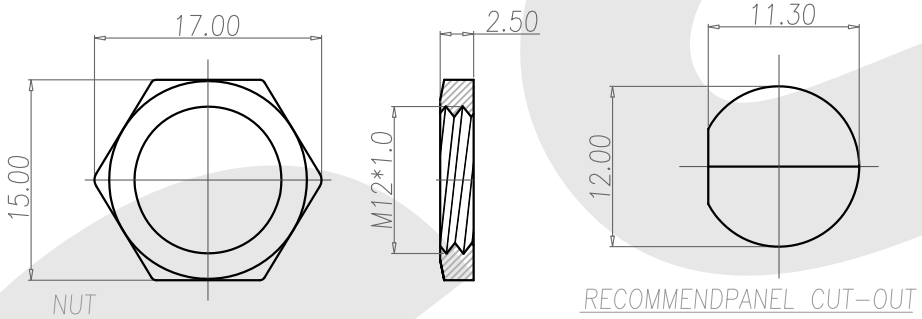
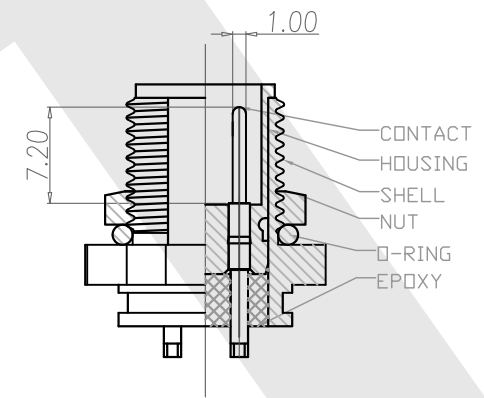
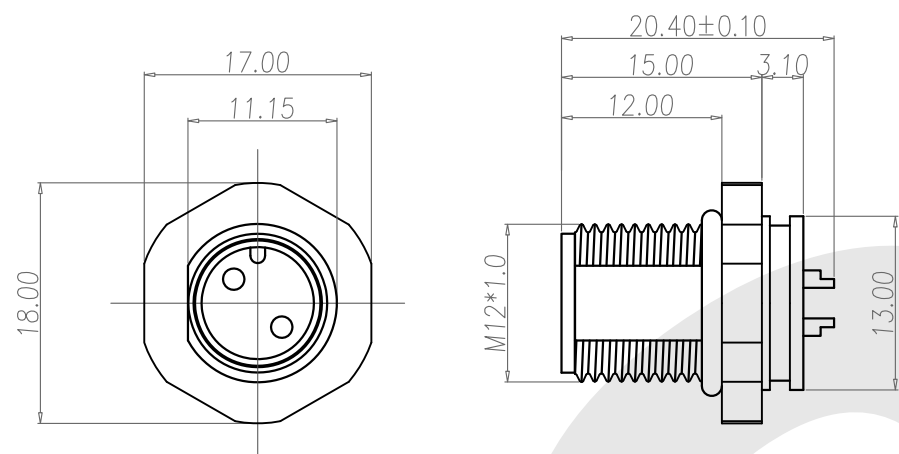

1. MATERIAL :
  - 1-1. HOUSING : PBT UL94V-0 ; COLOR : BLACK
  - 1-2. CONTACT : BRASS
  - 1-3. NUT : BRASS.
  - 1-4. SHELL : BRASS.
  - 1-5. O-RING : EPDM
2. FINISH :
  - 2-1. CONTACT : 10 MICRO INCHES MIN. GOLD PLATED  
UNDER PLATE : NICKEL
  - 2-2. NUT : NICKEL PLATED
  - 2-3. SHELL : NICKEL PLATED
3. ELECTRICAL SPECIFICATION :
  - 3-1. Rated current : 5A
  - 3-2. Rated Voltage : 125V
  - 3-3. Water proof : IPX7
4. Environmental :
  - 4-1. Operation Temperature : -40℃~85℃

TABLE A

12M2P-B-A-FL-12x1.0-S-S-G10-B-N-2X0	12M2P-B-A-FL-12x1.0-S-S-G10-B-N-2

**SST** SOUTH SEA TERMINAL CO.,LTD

SGS Report No.:	Customer:	Part No.:
		12M2P-B-A-FL-12x1.0-S-S-G10-B-N-2
Title: M12 MALE SOLDER TYPE FRONT LOCK for PANEL		
Drawn By: Storm.Li	SCALE	SHEET
Checked By: du	1:1	1/1
Approved By: Tony	REV.	A
	DWG NO.:	/
	Third angle Projection	Units
	General Dimension Tolerance	mm
	TOLERANCE:	
	.x	±0.20
	.xx	±0.10
	.xxx	±0.05
	.xxxx	±0.03
	ANGULA	±1°