

11	12	13	14
Rev	Revisions	Rev.Drawn	Date
A		Du	07.Mar.2013

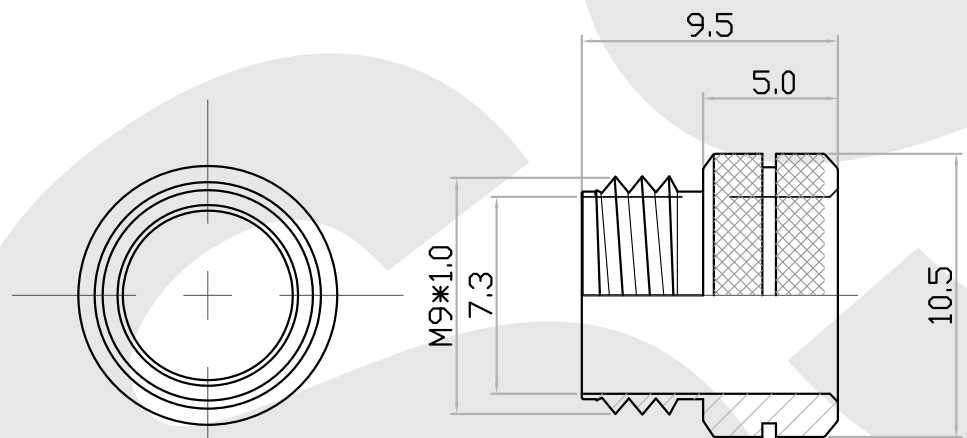
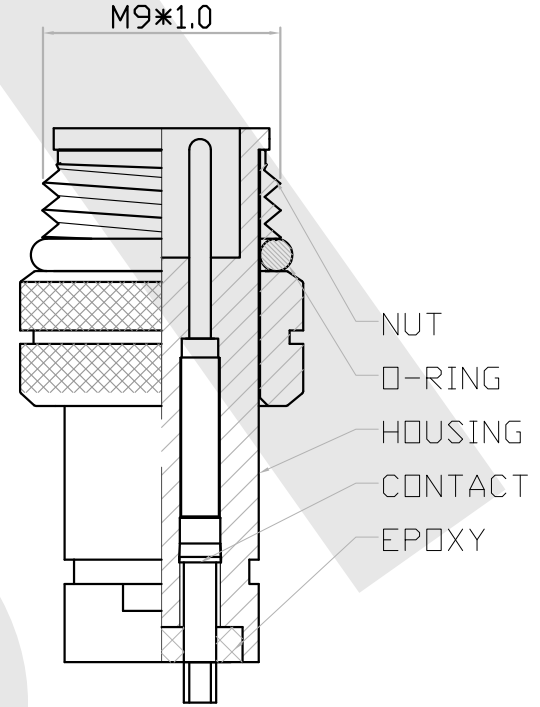
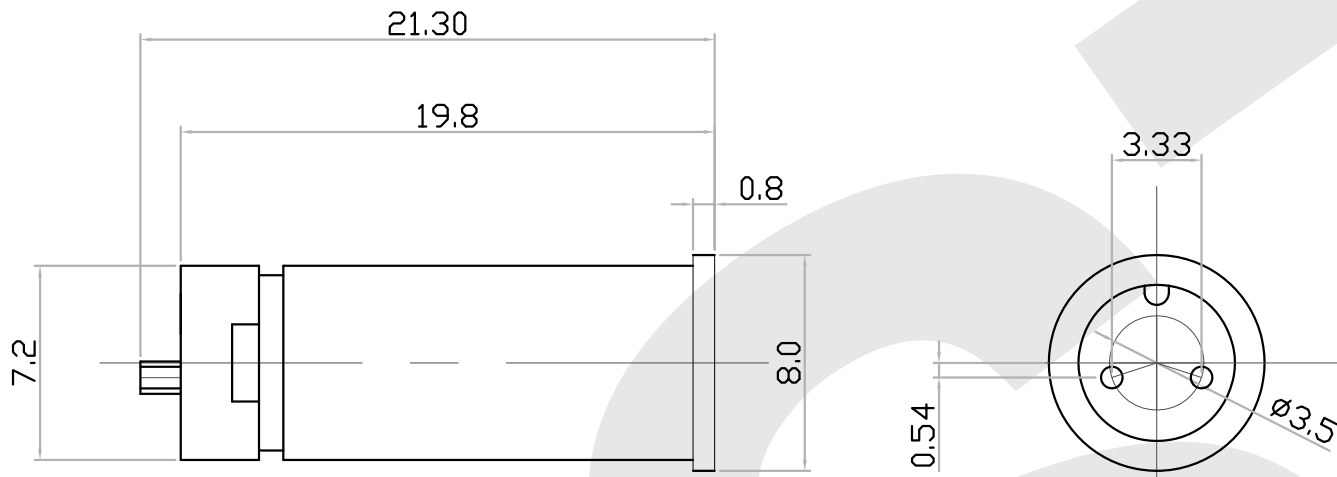

NUT

1. MATERIAL :
  - 1-1. HOUSING : PBT UL94V-0 ; COLOR : BLACK
  - 1-2. CONTACT : BRASS
  - 1-3. O-RING : NBR ; COLOR : BLACK
  - 1-4. NUT : BRASS
2. FINISH :
  - 2-1. CONTACT : 10 MICRO INCHES MIN. GOLD PLATED  
UNDER PLATE : NICKEL
  - 2-2. NUT : NICKEL PLATED.
3. ELECTRICAL SPECIFICATION :
  - 3-1. Rated current : 5A
  - 3-2. Rated Voltage :125V
  - 3-3. Water proof: IPX7
4. Environmental :
  - 4-1. Operation Temperature : -20 ℃~85℃

**SST** SOUTH SEA TERMINAL CO.,LTD

SGS Report No.:	Customer:	Part No.:			
	9M2P-W-A-9.5-P-2-G10-B-N				
Title:M9 MALE SOLDER TYPE for CABLE					
Drawn By:Storm.Li	SCALE	SHEET	REV.	DWG NO.:	TOLERANCE: .x ±0.20 .xx ±0.10 .xxx ±0.05 .xxxx ±0.03 ANGULA ±1°
Checked By:du	1:1	1/1	A	/	
Approved By: Tony	Third angle Projection			Units	
	General Dimension Tolerance				