

Rev	Revisions	Rev.Drawn	Date
A		Du	07.FEB.2012

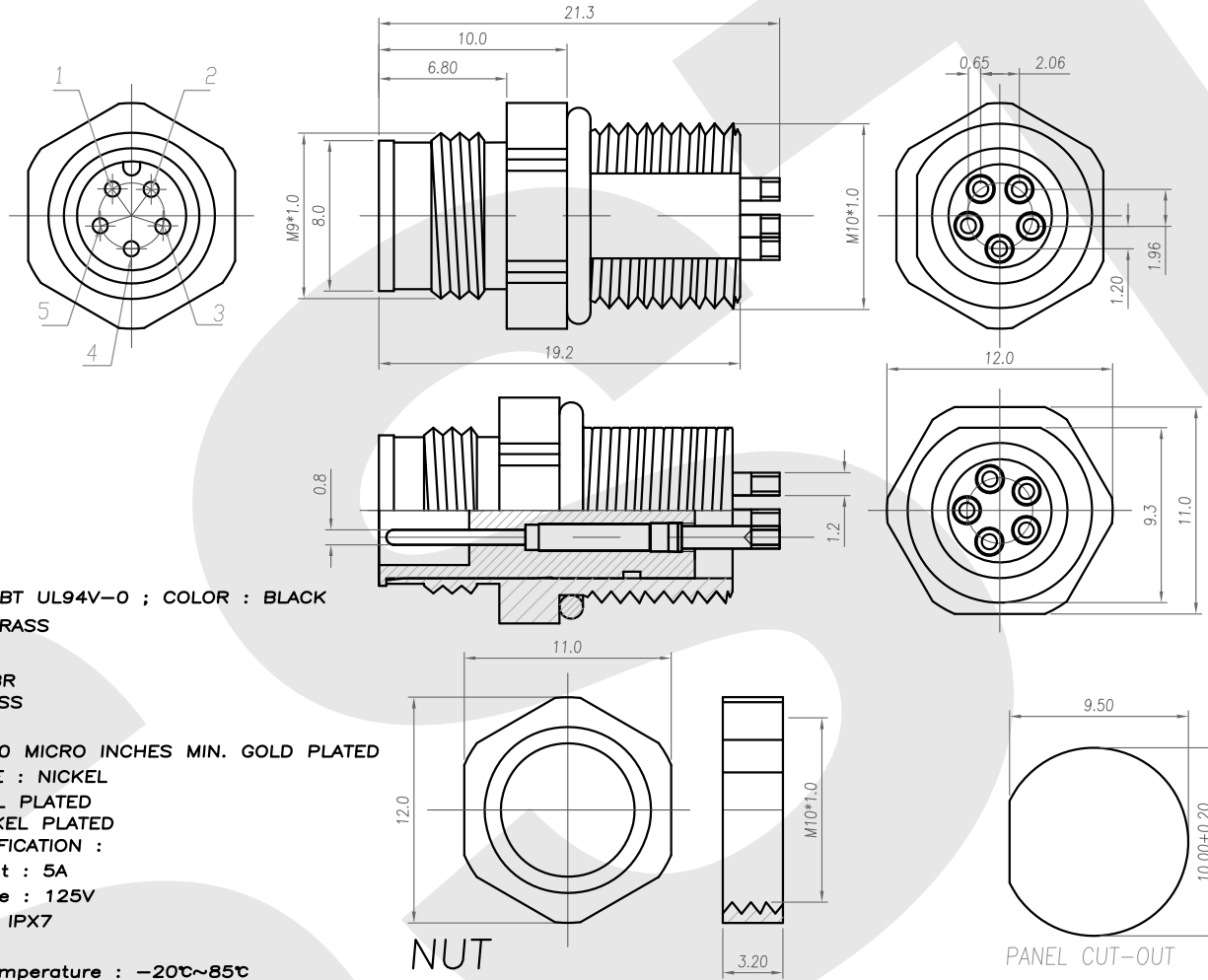

1. MATERIAL :
  - 1-1. HOUSING : PBT UL94V-0 ; COLOR : BLACK
  - 1-2. CONTACT : BRASS
  - 1-3. NUT : BRASS
  - 1-4. O-RING : NBR
  - 1-5. SHELL : BRASS
2. FINISH :
  - 2-1. CONTACT : 10 MICRO INCHES MIN. GOLD PLATED  
UNDER PLATE : NICKEL
  - 2-2. NUT : NICKEL PLATED
  - 2-3. SHELL : NICKEL PLATED
3. ELECTRICAL SPECIFICATION :
  - 3-1. Rated current : 5A
  - 3-2. Rated Voltage : 125V
  - 3-3. Water proof: IPX7
4. Environmental :
  - 4-1. Operation Temperature : -20℃~85℃

**SST** SOUTH SEA TERMINAL CO.,LTD

SGS Report No.: Customer: Part No.:  
9M5P-B-A-BL-10x1.0-S-S-G10-B-N

Title: M9 MALE SOLDER TYPE BACK LOCK for PANEL

Drawn By: Storm.Li	SCALE	SHEET	REV.	DWG NO.:	TOLERANCE:
Checked By: du	1:1	1/1	A	SST-120207-01	.x ±0.20
Approved By: Tony	Third angle Projection			Units mm	.xx ±0.10
	General Dimension Tolerance				.xxx ±0.05
					.xxxx ±0.03
					ANGULA ±1°