

Rev	Revisions	Rev.Drawn	Date
A		Du	07.Mar.2013

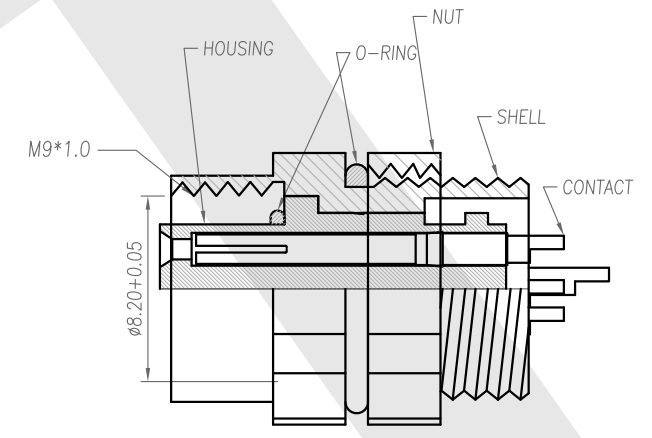

# ASSEMBLY

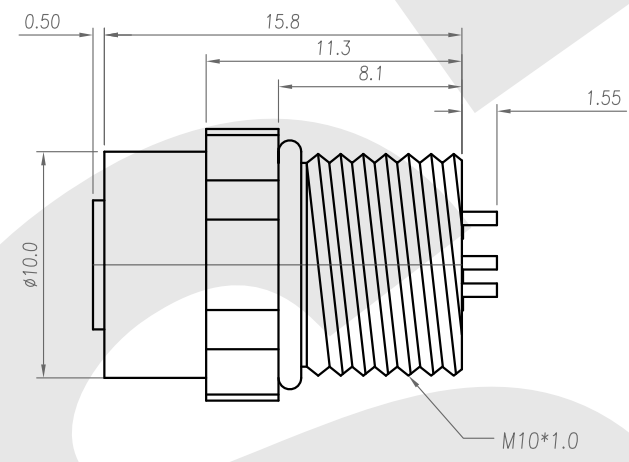
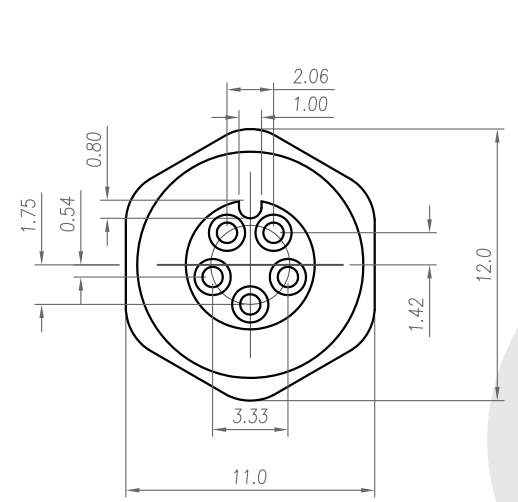
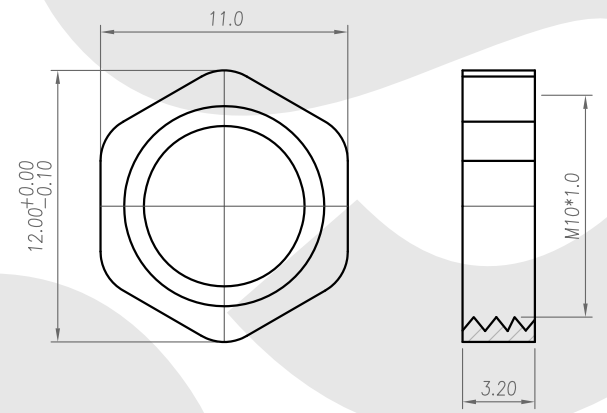
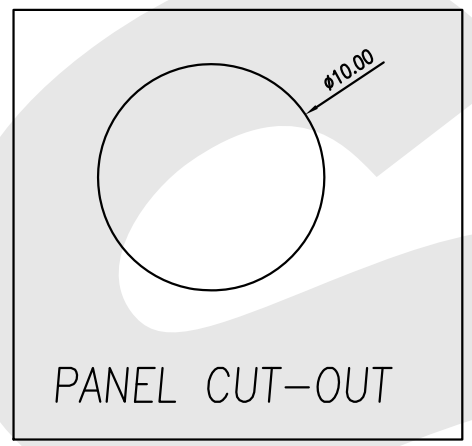

- MATERIAL :**
  - 1-1. HOUSING : PBT UL94V-0 ; COLOR : BLACK
  - 1-2. CONTACT : BRASS
  - 1-3. SHELL : BRASS
  - 1-4. O-RING:NBR
  - 1-5. NUT:BRASS
- FINISH :**
  - 2-1. CONTACT :
    - CONTACT AREA : 10 MICRO INCHES MIN. GOLD PLATED
    - SOLDER AREA : TIN
    - UNDER PLATE : NICKEL
  - 2-2. SHELL : NICKEL PLATED
  - 2-3. NUT : NICKEL PLATED
- ELECTRICAL SPECIFICATION :**
  - 3-1. Rated current : 5A
  - 3-2. Voltage :125V
  - 3-3. Water proof: IPX7
- Environmental :**
  - 4-1. Operation Temperature : -20℃~85℃

**SST SOUTH SEA TERMINAL CO.,LTD**

SGS Report No.:	Customer:	Part No.:
		9F5P-B-A-BL-10x1.0-C-S-G10-B-N
Title:M9 FEMALE SOLDER TYPE BACK LOCK for PANEL		
Drawn By:Storm.Li	SCALE	SHEET
Checked By:du	1:1	1/1
Approved By:Tony	REV.	A
	DWG NO.:	/
	Third angle Projection	Units
	General Dimension Tolerance	mm
	TOLERANCE:	
	.x	±0.20
	.xx	±0.10
	.xxx	±0.05
	.xxxx	±0.03
	ANGULA	±1°