

Rev	Revisions	Rev.Drawn	Date
A		Du	25.11.2008

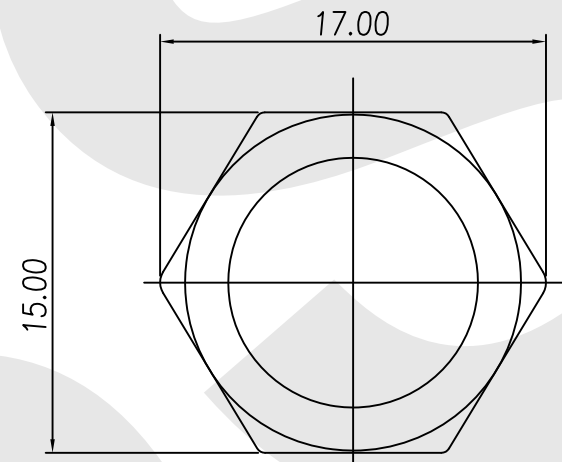

**NUT**

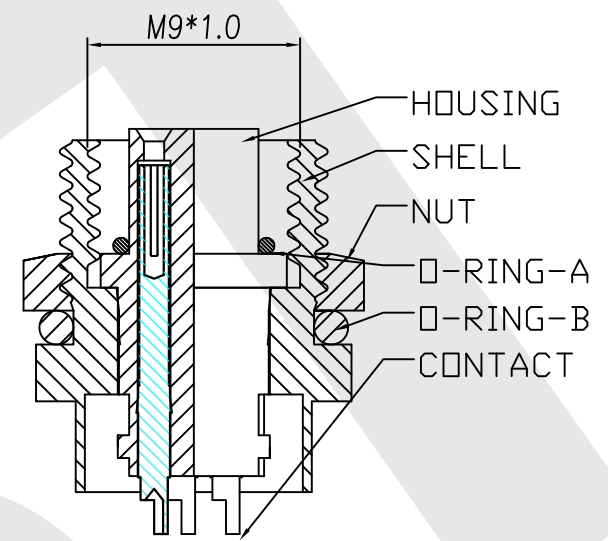
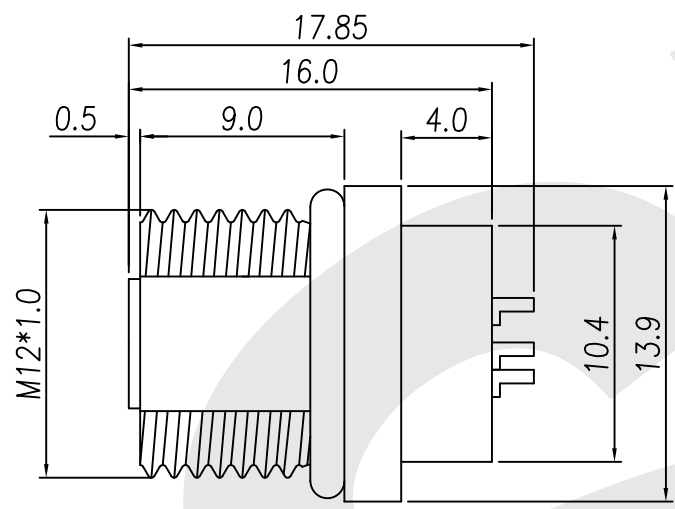
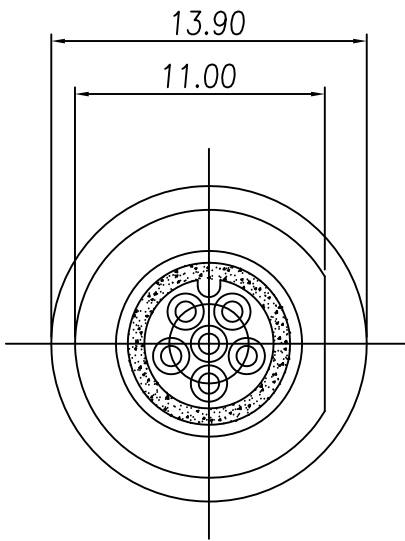
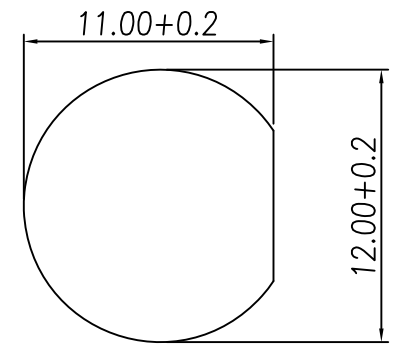
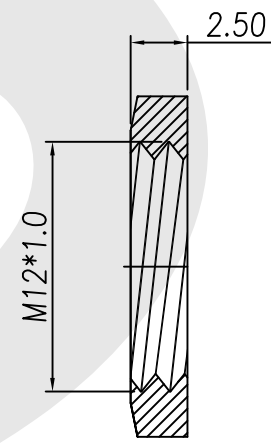

**PANEL CUT-OUT**

1. MATERIAL :
  - 1-1. HOUSING : PBT UL94V-0 ; COLOR : BLACK
  - 1-2. CONTACT : BRASS
  - 1-3. O-RING A : NBR; COLOR : BLACK
  - 1-4. O-RING B : EPDM ; COLOR : BLACK
  - 1-5. NUT : BRASS
2. FINISH :
  - 2-1. CONTACT : 10 MICRO INCHES MIN. GOLD PLATED UNDER PLATE : NICKEL
  - 2-2. NUT : NICKEL PLATED 60u" ~ 100u" OVER ALL
  - 2-3. SHELL : NICKEL PLATED 60u" ~ 100u" OVER ALL
3. ELECTRICAL SPECIFICATION :
  - 3-1. Rated current : 5A
  - 3-2. Voltage :125V
  - 3-3. Water proof: IPX7
4. Environmental :
  - 4-1. Operation Temperature : -20 ℃~85℃

**SST SOUTH SEA TERMINAL CO.,LTD**

SGS Report No.:	Customer:	Part No.:
		9F6P-B-A-FL-12x1.0-S-S-G10-B-N
Title:M9 FEMALE SOLDER TYPE FRONT LOCK for PANEL		
Drawn By:Storm.Li	SCALE	SHEET
Checked By:du	1:1	1/1
Approved By: Tony	REV.	A
	DWG NO.:	SST-081125-01
	TOLERANCE:	X. ±2MM
		.X ±0.25MM
		.XX ±0.1MM
		.XXX±0.1MM
	Third angle Projection	Units
	General Dimension Tolerance	mm