

Rev	Revisions	Rev.Drawn	Date
A		Du	15.SEP.2011

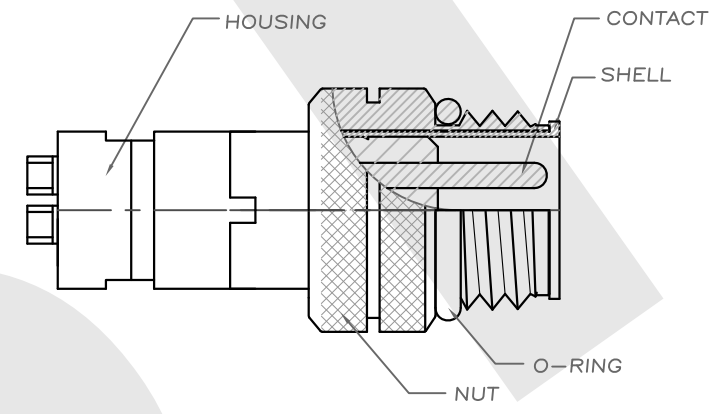

SECTION AA

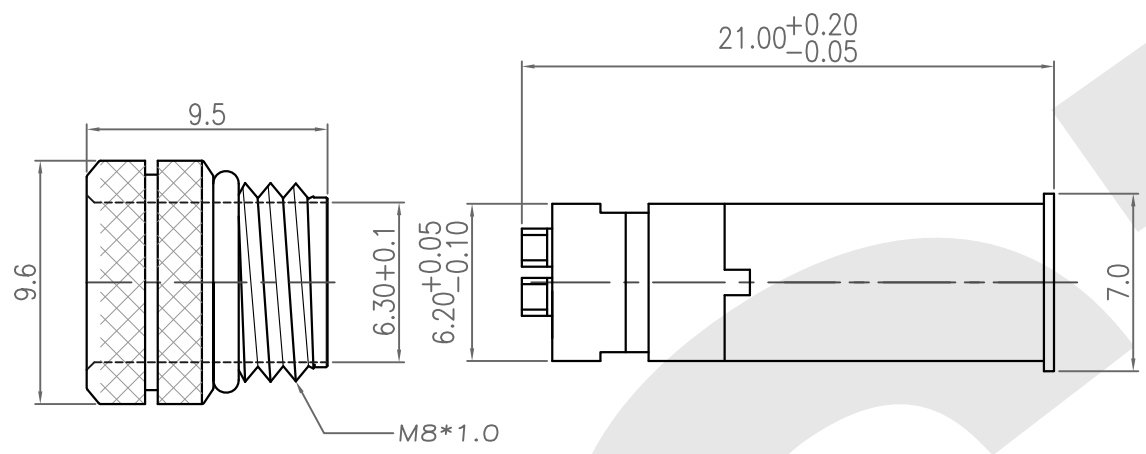
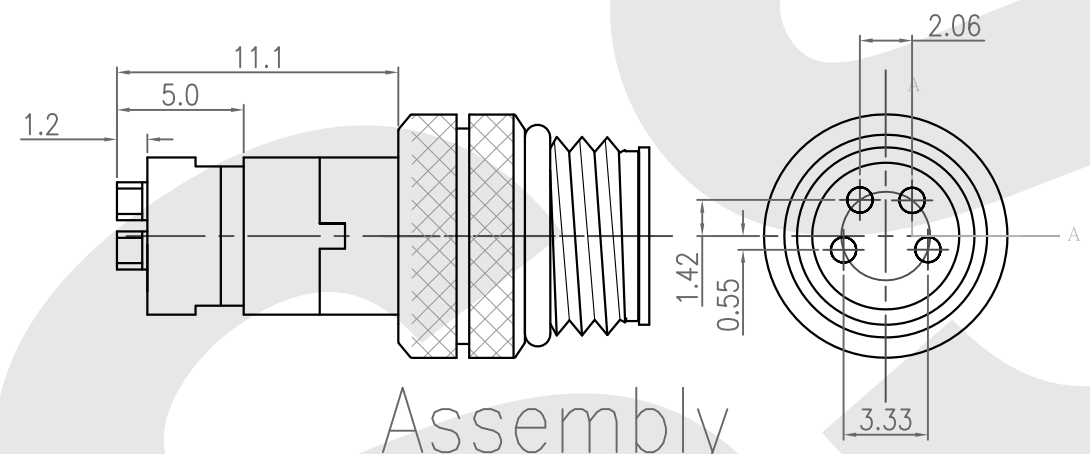

Assembly

- NOTE:**
- MATERIAL :**
    - 1-1. HOUSING : PBT UL94V-0 ; COLOR : BLACK
    - 1-2. CONTACT : BRASS
    - 1-3. SHELL : BRASS
    - 1-4. NUT : BRASS
    - 1-3. O-RING : NBR ; COLOR : BLACK
  - FINISH :**
    - 2-1. CONTACT :10 MICRO INCHES MIN. GOLD PLATING OVER NICKEL
    - 2-2. SHELL : NICKEL PLATED 60u"~100u"
    - 2-2. NUT : NICKEL PLATED 60u" ~ 100u" OVER ALL
  - ELECTRICAL SPECIFICATION :**
    - 3-1. Rated current : 5A
    - 3-2. Voltage :125V
    - 3-3. Water proof: IPX7
  - Environmental :**
    - 4-1. Operation Temperature : -40 ℃~85℃

**SST SOUTH SEA TERMINAL CO.,LTD**

SGS Report No.:	Customer:	Part No.:	8M4P-W-E-9.5-M-1-G10-B-N-1		
Title:		M8 MALE SOLDER TYPE for CABLE (GROUND)			
Drawn By: Storm.Li	SCALE	SHEET	REV.	DWG NO.:	TOLERANCE:
Checked By: du	1:1	1/1	A	SST-110915-02	.x ±0.20
Approved By: Tony	Third angle Projection		General Dimension Tolerance		.xx ±0.10
	Units		mm		.xxx ±0.05
					.xxxx ±0.03
					ANGULA ±1'