

Rev	Revisions	Rev.Drawn	Date
A		Du	25.11.2008

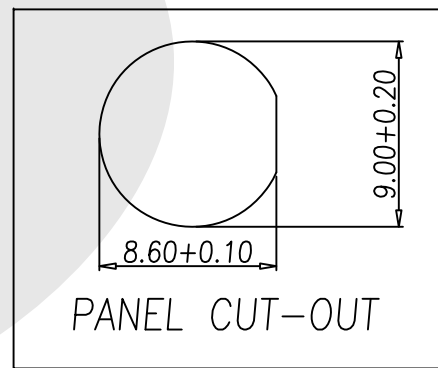
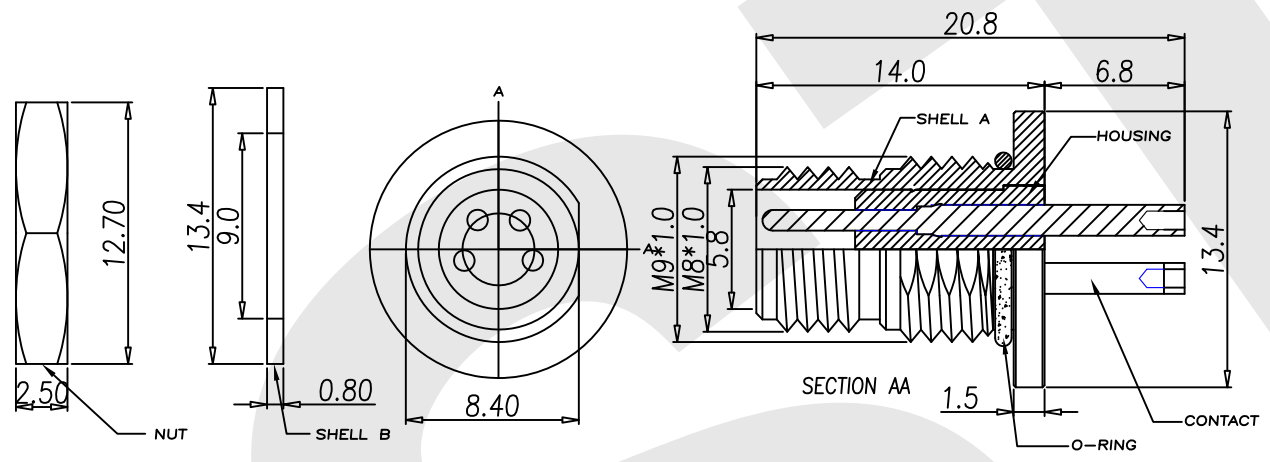

1. MATERIAL :
  - 1-1. HOUSING : PBT UL94V-0 ; COLOR : BLACK
  - 1-2. CONTACT A : BRASS
  - 1-3. SHELL A: BRASS
  - 1-4. SHELL B : BRASS
  - 1-5. NUT : BRASS
  - 1-6. O-RING :EPDM; COLOR : BLACK
2. FINISH :
  - 2-1. CONTACT A : 10 MICRO INCHES MIN. GOLD PLATED UNDER PLATE : NICKEL
  - 2-2. SHELL A : NICKEL PLATED 60u" ~ 100u" OVER ALL
  - 2-3. SHELL B : NICKEL PLATED 60u" ~ 100u" OVER ALL
3. ELETRICAL SPECIFICATION :
  - 3-1. Rated current : 5A
  - 3-2. Voltage :125V
  - 3-3. Water proof: IPX7
4. Environmental :
  - 4-1. Operation Temperature : -40 ℃~85℃

SGS Report No.:		Customer:		Part No.:	
				8M4P-B-E-FL-9x1.0-S-S-G10-B-N	
Title: M8 MALE SOLDER TYPE FRONT LOCK for PANEL					
Drawn By: Storm.Li	SCALE	SHEET	REV.	DWG NO.:	TOLERANCE:
Checked By: du	1:1	1/1	A	SST-081125-01	X. ±2MM .X ±1MM .XX ±0.1MM .XXX±0.1MM
Approved By: Tony	Third angle Projection			Units mm	
	General Dimension Tolerance				