

Rev	Revisions	Rev.Drawn	Date
A		Du	07.Mar.2013

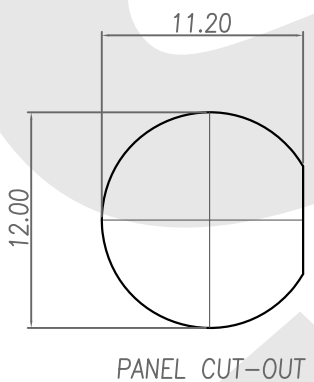
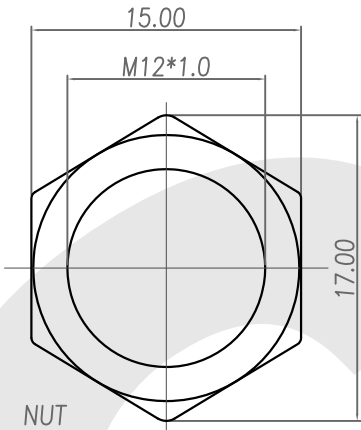
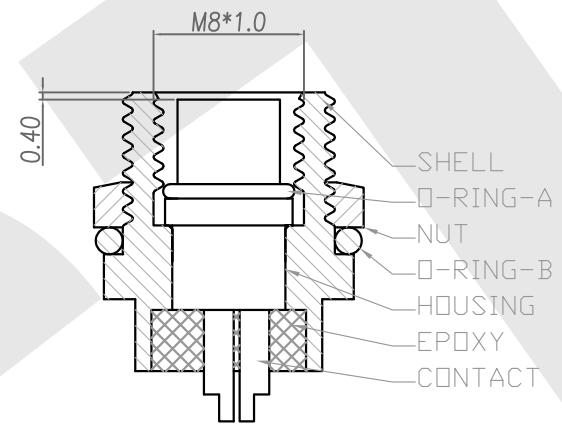
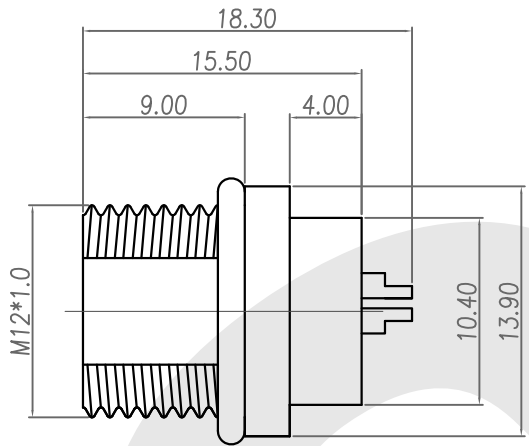
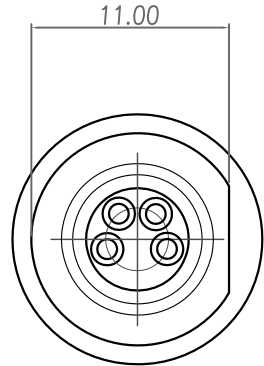

1. MATERIAL :
 - 1-1. HOUSING : PBT UL94V-0 ; COLOR : BLACK
 - 1-2. CONTACT : BRASS
 - 1-3. NUT : BRASS
 - 1-4. SHELL : BRASS
 - 1-5. O-RING-A : NBR ; COLOR : BLACK
 - 1-6. O-RING-B : EPDM ; COLOR : BLACK
2. FINISH :
 - 2-1. CONTACT : 10 MICRO INCHES MIN. GOLD PLATED
UNDER PLATE : NICKEL
 - 2-2. NUT : NICKEL PLATED
 - 2-3. SHELL : NICKEL PLATED
3. ELECTRICAL SPECIFICATION :
 - 3-1. Rated current : 5A
 - 3-2. Rated Voltage : 125V
 - 3-3. Water proof : IPX7
4. Environmental :
 - 4-1. Operation Temperature : -20℃~85℃

SST SOUTH SEA TERMINAL CO.,LTD

SGS Report No.:	Customer:	Part No.:
		8F4P-B-E-FL-12x1.0-S-S-G10-B-N-2
Title: M8 FEMALE SOLDER TYPE FRONT LOCK for PANEL		
Drawn By: Storm.Li	SCALE	SHEET
Checked By: du	1:1	1/1
Approved By: Tony	REV.	A
	DWG NO.:	/
	Units	mm
	TOLERANCE:	
	.x ±0.20	
	.xx ±0.10	
	.xxx ±0.05	
	.xxxx ±0.03	
	ANGULA ±1°	