

Rev	Revisions	Rev.Drawn	Date
A		Du	25.11.2008

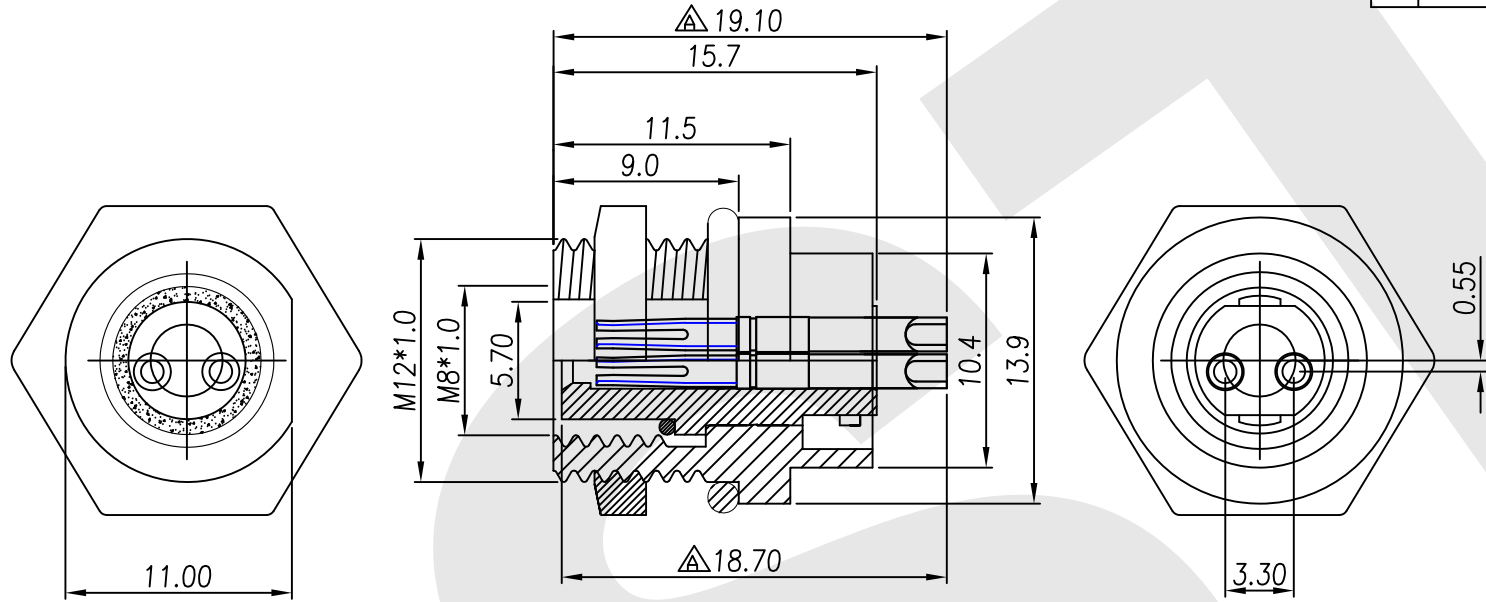

NOTE:

1. MATERIAL :
 - 1-1. HOUSING : PBT UL94V-0 ; COLOR : BLACK
 - 1-2. CONTACT : PHOSPHOR BRONZE
 - 1-3. NUT : BRASS
 - 1-4. O-RING : NBR ; COLOR : BLACK
2. FINISH :
 - 2-1. CONTACT : CONTACT AREA : 10 MICRO INCHES MIN. GOLD PLATING
UNDER PLATE : NICKEL
 - 2-2. NUT : NICKEL PLATED 60u" ~ 100u" OVER ALL
3. ELECTRICAL SPECIFICATION :
 - 3-1. Rated current : 5A
 - 3-2. Voltage :125V
 - 3-3. Water proof: IPX7
4. Environmental :
 - 4-1. Operation Temperature : -20 ℃~85℃

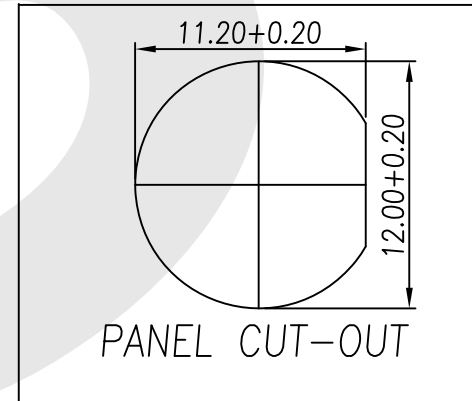

SST SOUTH SEA TERMINAL CO.,LTD

SGS Report No.:	Customer:	Part No.:
		8F2P-B-E-FL-12x1.0-S-S-G10-B-N-1
Title: M8 FEMALE SOLDER TYPE FRONT LOCK for PANEL		
Drawn By: Storm.Li	SCALE	SHEET
Checked By: du	1:1	1/1
Approved By: Tony	REV.	A
	DWG NO.:	SST-081125-01
	TOLERANCE:	X. ±2MM .X ±1MM .XX ±0.1MM .XXX±0.1MM
	Third angle Projection	Units
	General Dimension Tolerance	mm