

Rev	Revisions	Rev.Drawn	Date
A		Du	22.Mar.2013

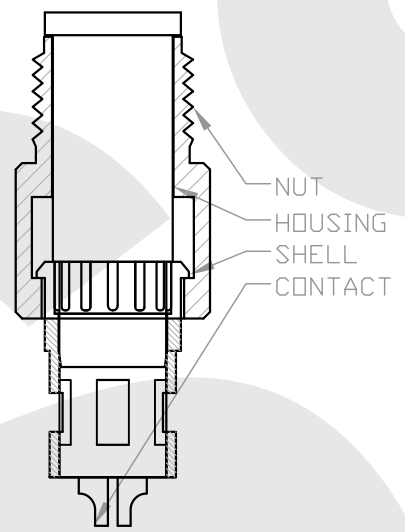
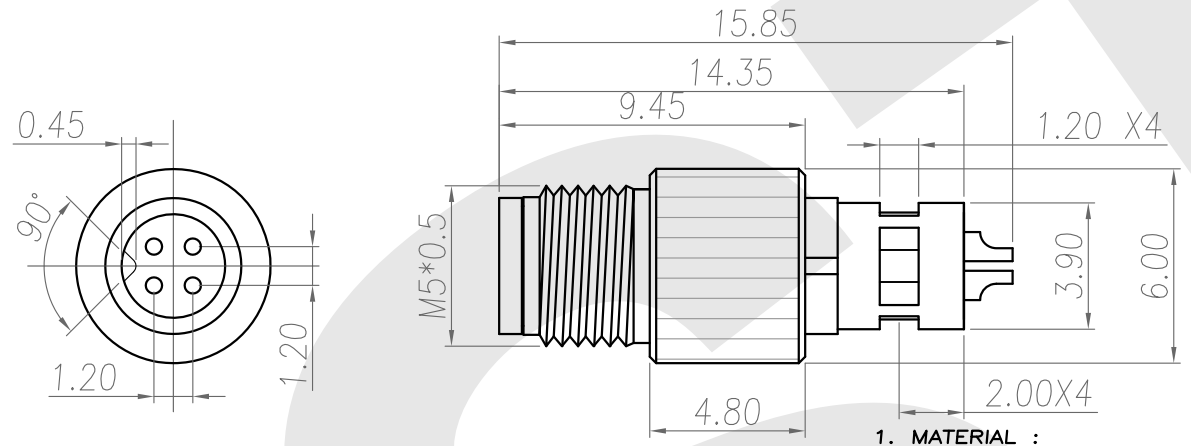

1. MATERIAL :
 - 1-1. HOUSING : SEE TABLE A.
 - 1-2. CONTACT : BRASS.
 - 1-3. NUT : BRASS
 - 1-4. SHELL : BRASS.
2. FINISH :
 - 2-1. CONTACT : GOLD FLASH MICRO INCHES MIN.
 - 2-2. NUT : SATING Ni PLATED.
 - 2-3. SHELL : BRIGHT TIN PLATED .
3. ELECTRICAL SPECIFICATION :
 - 3-1. Rated current : 1A
 - 3-2. Rated Voltage : 60V
 - 3-3. Water proof : IP67
4. Environmental :
 - 4-1. Operation Temperature : -20 ℃~85℃

5M4P-W-A-8.4-M-1-GF-B-SN (T)	TPU ; COLOR : BLACK
5M4P-W-A-8.4-M-1-GF-B-SN (P)	PBT ; COLOR : BLACK
PART NO	MATERIAL

SST SOUTH SEA TERMINAL CO.,LTD

SGS Report No.:	Customer:	Part No.:
		5M4P-W-A-8.4-M-1-GF-B-SN
Title: M5 MALE SOLDER TYPE for CABLE (GROUND)		
Drawn By: Storm.Li	SCALE	SHEET
Checked By: du	1:1	1/1
Approved By: Tony	REV.	A
	DWG NO.:	/
	Third angle Projection	
	General Dimension Tolerance	
	Units	mm
	TOLERANCE:	
	.x	±0.20
	.xx	±0.10
	.xxx	±0.05
	.xxxx	±0.03
	ANGULA	±1°