

Rev	Revisions	Rev.Drawn	Date
A		Du	31,May,2011

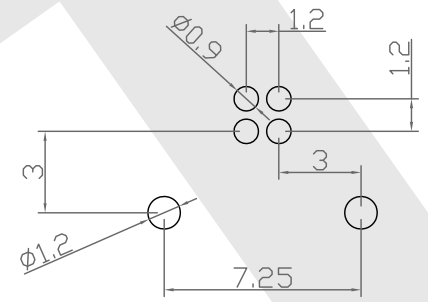

P.C.B LAYOUT

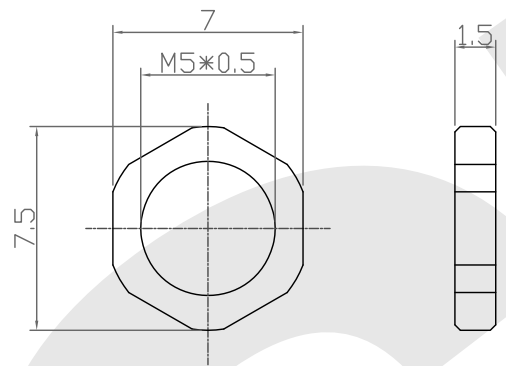
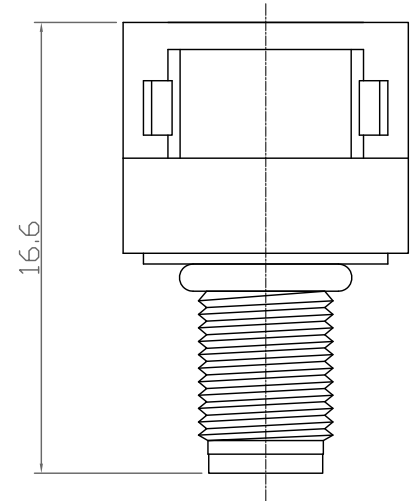
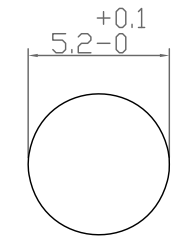
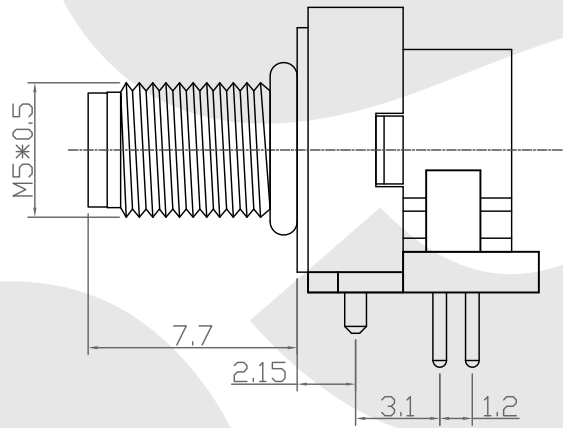
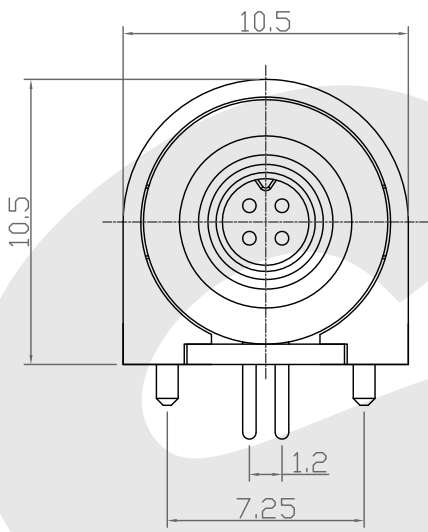

PANEL CUT-OUT

NUT

NOTE:

1. MATERIAL :
 - 1-1. HOUSING : PBT UL94V-0 ; COLOR : BLACK
 - 1-2. CONTACT : BRASS
 - 1-3. NUT : BRASS
 - 1-4. O-RING : NBR ; COLOR : BLACK
 - 1-5. BACK HOUSING : PBT UL94V-0 ; COLOR : BLACK
 - 1-6. DOWN HOUSING : PBT UL94V-0 ; COLOR : BLACK
2. FINISH :
 - 2-1. CONTACT : GOLD FLASH ON OVER ALL
UNDER PLATE : NICKEL
 - 2-2. NUT : NICKEL PLATED
 - 2-3. SHELL : STAIN NICKEL 80u"~100u" ON OVER ALL

SST SOUTH SEA TERMINAL CO.,LTD

SGS Report No.:	Customer:	Part No.:
		5M4P-B-RA-A-FL-5x0.5-C-D-GF-B-N
Title: M5 MALE 90° DIP TYPE for BOARD		
Drawn By: Storm.Li	SCALE	SHEET
Checked By: du	1:1	1/1
Approved By: Tony	REV. A	
	DWG NO.:	SST-110531-25
	Third angle Projection	Units
	General Dimension Tolerance	mm
		TOLERANCE
		.x ±0.20
		.xx ±0.10
		.xxx ±0.05
		.xxxx ±0.03
		ANGULA ±1°